

**TALAT Lecture 4703**

# **Adhesive Joints - Design and Calculation**

9 pages, 10 figures

Basic Level

**prepared by  
Lutz Dorn, Technische Universität, Berlin**

## **Objectives:**

- to describe the basic types of loadings of adhesive joints and to give examples of recommended joint designs
- to calculate the strength of adhesive joints

## **Prerequisites:**

- general background in production engineering and material science
- background in mechanics and polymer science

**Date of Issue: 1994**

© EAA - European Aluminium Association

# 4703 Design and Calculation of Adhesive Joints

## Table of Contents

4703 Design and Calculation of Adhesive Joints .....	2
<b>4703.01 Design Recommendations for Adhesive Joints.....</b>	<b>2</b>
Basic Types of Loadings of Adhesive Joint Geometries .....	2
Examples for Joint Designs .....	4
<b>4703.02 Calculation of Adhesive Joint Strength .....</b>	<b>6</b>
<b>4703.03 Application Examples.....</b>	<b>7</b>
<b>4703.04 Literature/ References .....</b>	<b>8</b>
<b>4703.05 List of Figures.....</b>	<b>9</b>

## 4703.01 Design Recommendations for Adhesive Joints

- Basic types of loadings of adhesive joint geometries
- Examples for joint designs:
  - Design of corner joints
  - Design of hollow section joints
  - Design of tube joints

### Basic Types of Loadings of Adhesive Joint Geometries

Just as in the case of welding, the adhesive joint has to be specially optimised for adhesive joining in order to have a joint of optimal strength.

Of the possible loading types which an adhesive joint can be subjected to, it is most suited for shear, torsion and compressive loads.

Tensile and in particular cleavage or peeling forces should be avoided (**Figure 4703.01.01**).

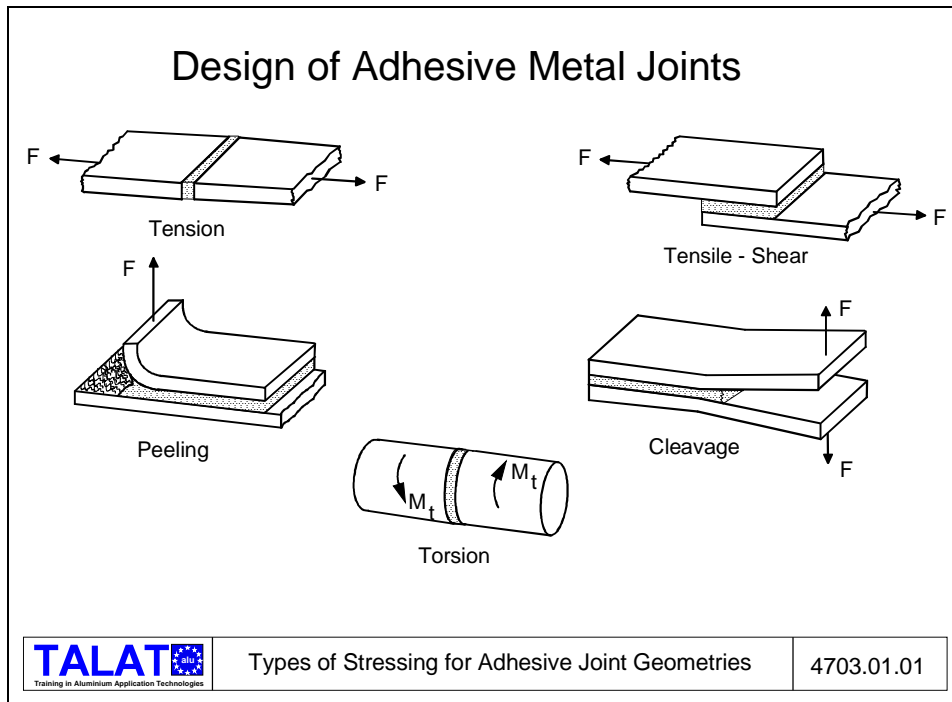

Design types which avoid peeling stresses in adhesive joints of metals are illustrated in **Figure 4703.01.02**.

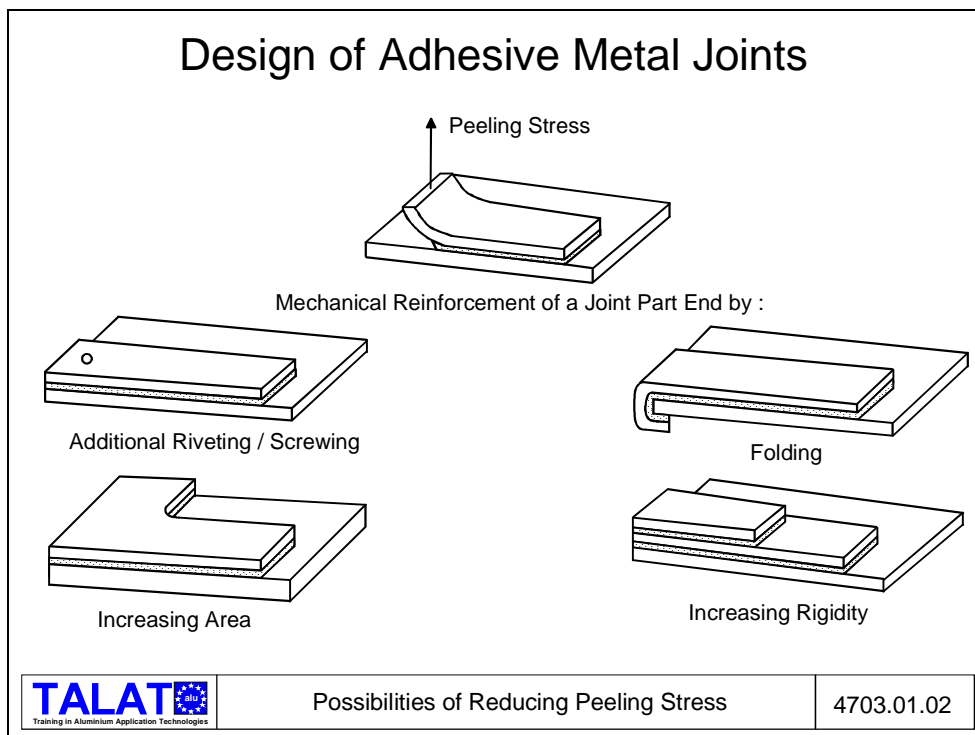

Besides the most widely used (one-sided) lap joints shown in **Figure 4701.01.01**, **Figure 4703.01.03** illustrates further possible designs for constructing overlapping adhesive joints. Scarf joints are most suitable for tensile-shear loading since the load distribution is favourable. These joints can, however, be used only for large joint part thicknesses and are complicated to manufacture

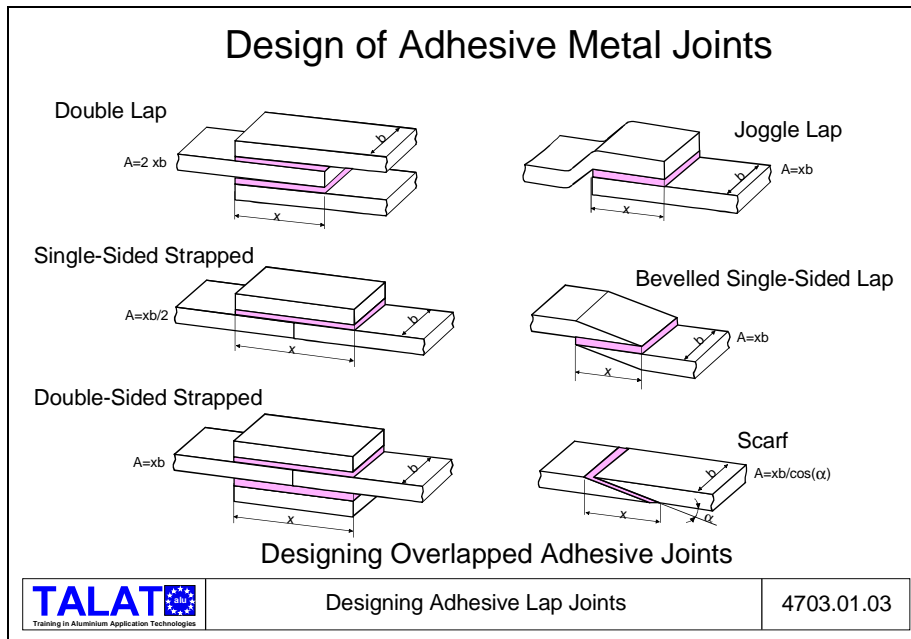

### Examples for Joint Designs

Designs which have proved most successful for corner joints, closed-sectioned profile joints and tube joints are illustrated in **Figure 4703.01.04**, **Figure 4703.01.05**, and **Figure 4703.01.06**. While joining tubes of different coefficients of thermal expansion adhesively, the tube with the larger expansion should be designed to be on the outside.

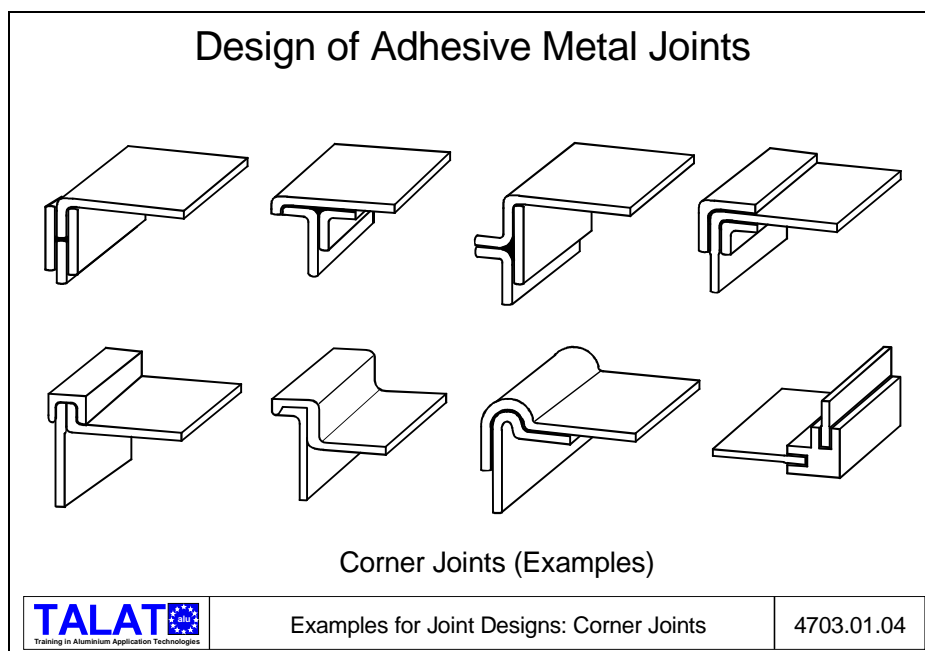

## Design of Adhesive Metal Joints

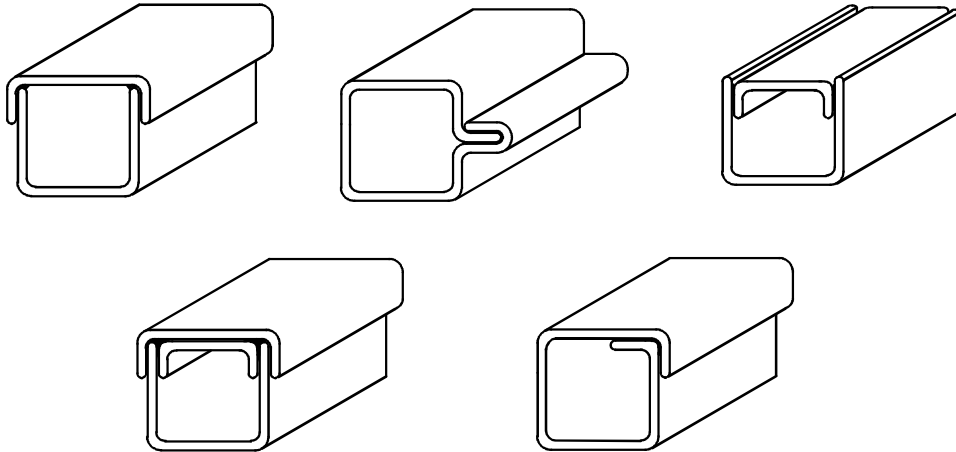

Closed Profiles (Examples)



Examples for Joint Designs: Closed Profiles

4703.01.05

## Design of Adhesive Metal Joints

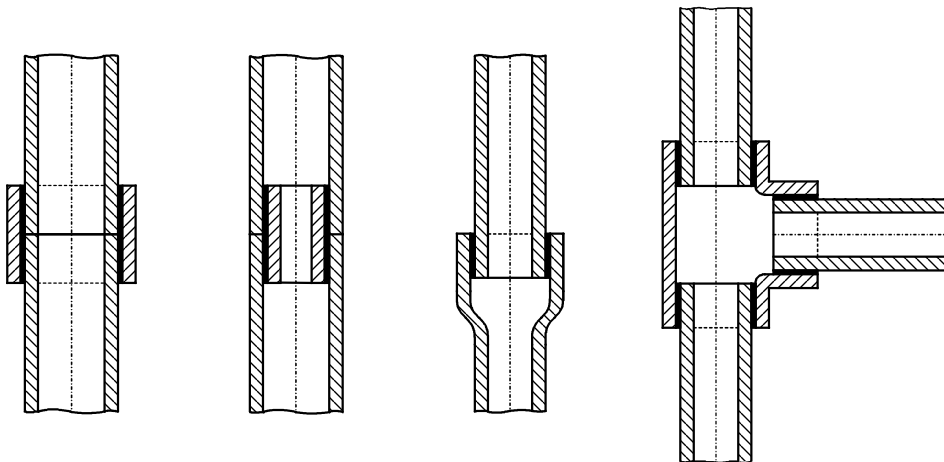

Tube Joints (Examples)



Examples for Joint Designs: Tube Joints

4703.01.06

## 4703.02 Calculation of Adhesive Joint Strength

Figure 4703.02.01 shows a rough method of calculating the strength of a single-sided lap joint based on a simplified form of the Volker equation according to Schliekelmann.

Calculation of Adhesive Joints		
The Mean Tensile-Shear Stress at Failure of Adhesive $\tau_{B\ m}$ is:	$\tau_{B\ m} = K \cdot M \cdot f$	
where the Adhesive Factor is:	$K = \tau_{B\ max} \cdot \sqrt{\frac{2d}{G}}$	
	$\tau_{B\ max}$ = max. Tensile-Shear Stress at Failure of Adhesive Joint	
	d = Adhesive Layer Thickness	
	G = Shear Modulus	
and the Metal Factor is:	$M = \sqrt{E}$	
	E = Modulus of Elasticity of Joint Material	
and the Design Factor is:	$f = \frac{\sqrt{s}}{l_o}$	
	s = Joint Thickness	
	$l_o$ = Overlap Length	
This results in the Following Final Equation for the Mean Tensile-Shear Stress:	$\tau_{B\ m} = \tau_{B\ max} \cdot \sqrt{\frac{2Esd}{Gl_o^2}}$	
	Calculation of Adhesive Joints	4703.02.01

Depending on the application, it is necessary to choose the appropriate safety factor as well as a number of design and load-dependent reducing factors.

### 4703.03 Application Examples

Typical application examples for adhesively joint metal constructions are layered or laminated, shell and sandwich constructions **Figure 4703.03.01**, **Figure 4703.03.02**, and **Figure 4703.03.03**. Sandwich constructions are only possible with adhesive joining.

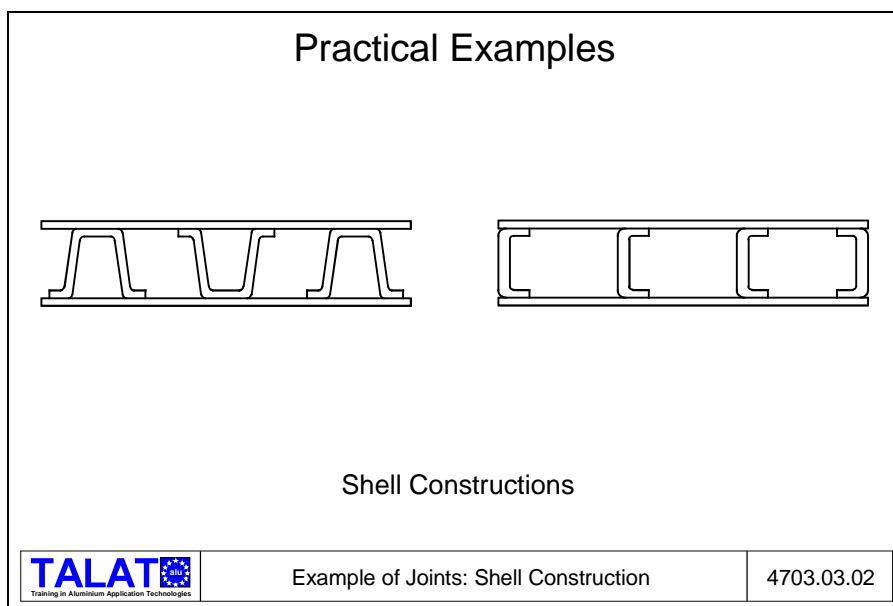
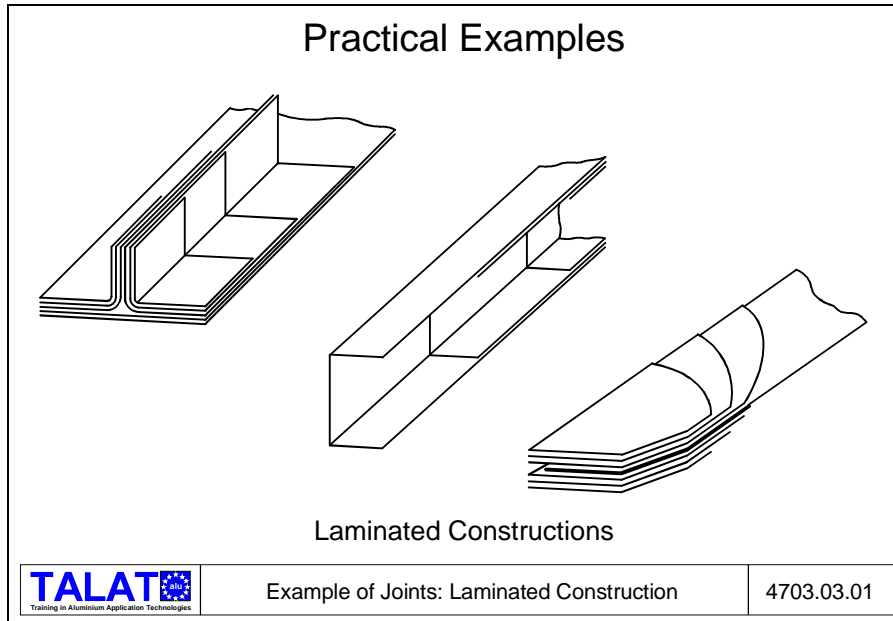

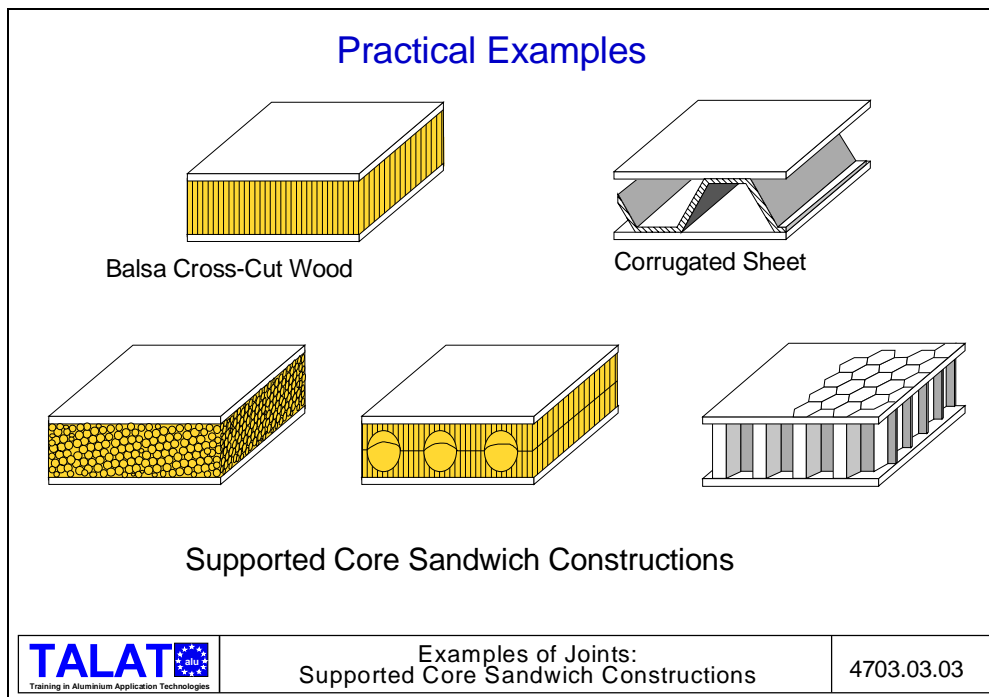

Other applications where adhesive joints are being successfully used are, for example, shaft-hub joints, screw-locking, sealing, in combination with other joining methods i.e., spot welding, riveting or folding.

#### 4703.04 Literature/ References

1. **Schliekelmann, R.J.:** Klebtechnische Erfahrungen aus dem Flug- und Raumfahrzeugbau. Zeitschriften für Schweißtechnik (Schweiz) 16 (1966), H. 8, S. 319-327.
2. **Schliekelmann, R.J.:** Metallkleben - Konstruktion und Fertigung in der Praxis. DVS Verlag Düsseldorf, 1972.
3. **Adam, R. and Wake, W.:** Structural adhesive joints in engineering. Elsevier Applied Science Publishers London and New York 1984.
4. **Hart-Smith, L.J.:** Designing adhesive bonds. Adhesives Age 21 (1978) 10, S. 32-37.
5. **Hart-Smith, L.J.:** Further developments in the design and analysis of adhesive-bonded structural joints. ASTM STP 749, ed by K.T. Kedward, American Society for Testing and Materials 1980, pp-3-31.



6. **Dorn, L.** und **Salem, N.:** Klebgerechtes Gestalten von Kunststoff-Metall-Klebverbindungen. Maschinenmarkt Würzburg 99 (1993) Nr. 35, S. 66-72.
7. **Schlimmer, M.:** Formulierung des Klebstoffverhaltens im Zugscherversuch mit Berücksichtigung der Schädigung. Schweißen und Schneiden 38 (1986) H. 11, S. 545-550.
8. **Kinloch, A.J.** and **Smart, N.R.:** Bonding and failure mechanisms in aluminium alloy adhesive joints. Journal of Adhesion 12 (1981), pp. 23-35.

### 4703.05 List of Figures

<b>Figure No.</b>	<b>Figure Title (Overhead)</b>
4703.01.01	Types of Stressing for Adhesive Joint Geometries
4703.01.02	Possibilities of Reducing Peeling Stress
4703.01.03	Designing Adhesive Lap Joints
4703.01.04	Examples for Joint Designs: Corner Joints
4703.01.05	Examples for Joint Designs: Closed Profiles
4703.01.06	Examples for Joint Designs: Tube Joints
4703.02.01	Calculation of Adhesive Joints
4703.03.01	Example of Joints: Laminated Construction
4703.03.02	Example of Joints: Shell Construction
4703.03.03	Example of Joints: Supported Core Sandwich Constructions