

TALAT Lecture 4101

Definition and Classification of Mechanical Fastening Methods

19 pages, 20 figures

Basic Level

prepared by Lothar Budde, Universität-Gesamthochschule Paderborn

Objectives:

- to introduce the principal types of mechanical fastening methods, i.e. screw joints, folding, riveting and clinching by definitions and classification
- to illustrate the great variety of types of mechanical fastening methods and systems available for joining aluminium parts

Prerequisites:

- General mechanical engineering background

Date of Issue: 1994

© EAA - European Aluminium Association

4101 Definition and Classification of Mechanical Fastening Methods

Table of Contents

4101 Definition and Classification of Mechanical Fastening Methods	2
4101.01 Introductory Remarks	3
Tendency of Developments in the Joining Technology.....	3
Joining Systems for Thin-walled Aluminium Components.....	4
Aims of the Mechanical Fastening Processes	4
Classification of Mechanical Fastenings Used in the Fabrication Technology	5
Elementary and Combined Joints	6
4101.02 Screw Joints	6
Construction Types for Screw Joints	6
Requirements for Screw Joints	7
Types of Screw Joints for Thin Sheets.....	7
Working Principle of Flow-Drilling Screws	8
Screw Joints for Aluminium Profiles.....	9
4101.03 Folds	10
Steps in the Folding Process for Straight-Edged Sheets	10
Widths of Overlaps in Folded Joints.....	10
4101.04 Rivet Joints	11
Joining by Riveting	11
Rivet Types for the Indirect Riveting of Aluminium.....	12
Commercially Available Rivet Forms and their Fields of Application	13
Working Principle of a Blind (Pop) Rivet	13
Choice of Fastening Elements for Mechanical Fastening Methods.....	14
4101.05 Clinching	15
Schematic Illustration of Clinching Joints, with or without Local Incision	15
An Aluminium Car Door Aggregate Carrier with Clinch Joints	16
4101.06 Summary	17
Comparison of the Technological Characteristics of Fastening Methods	17
4101.07 Literature/References	18
4101.08 List of Figures	19

Joining is in many cases an important and often critical process step in the manufacturing of aluminium components from shaped sheet and/or profiles. Mechanical fabricating processes fulfil the ever increasing demands on the joining quality and reproducibility during manufacturing as well as quality assurance. These have low investment costs, are easy to use and can be easily adapted for automatic processes.

4101.01 Introductory Remarks

- Tendency of developments in the joining technology
- Joining systems for thin-walled aluminium components
- Aims of the mechanical fastening processes
- Classification of mechanical fastenings used in the fabrication technology
- Elementary and combined joints

Tendency of Developments in the Joining Technology

Due to technological and economical pressures, a large number of fabricating companies have to reconsider their concepts regarding joining technologies used for joining in aluminium constructions.

The aim of new and newest developments in fastening techniques is to introduce methods for fastening new materials, and to improve both reliability as well as economy of the process (**Figure 4101.01.01**).

<h3>Main Aims of Improvements and New Developments in the Joining Technology</h3>		
→	To Improve the Economics and Degree of Automation	
→	To Improve the Reliability of the Joining Process	
→	To Make Joining Technologies Available for new Materials and Fields of Application	
<small>Source: Bahre</small>		
	Tendency of Developments in the Joining Technology	4101.01.01

Joining Systems for Thin-walled Aluminium Components

According to the development trends, two main methods can be used for joining aluminium: the "classical" (proven, standard) and "new" (less known and seldom used) methods.

Besides this rather imprecise definition, a further classification is possible, based on the geometry of the process and on the possibility of joining different materials and, for that matter, non-metallic materials with each other (see **Figure 4101.01.02**).

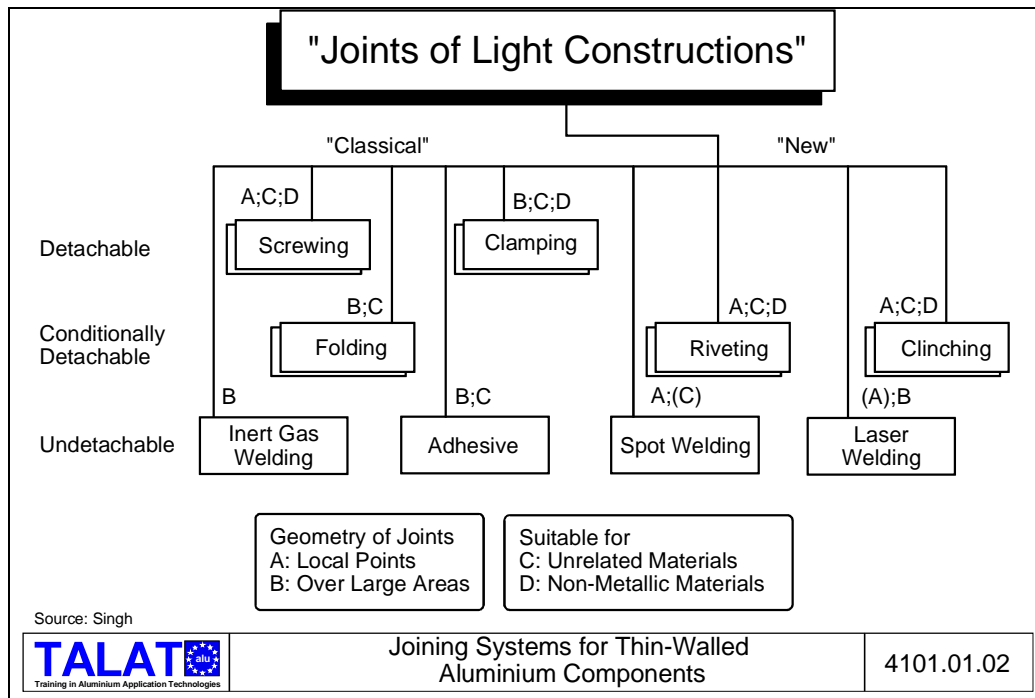

Aims of the Mechanical Fastening Processes

Mechanical fastening methods are gaining in popularity, both in the assembly as well as for mass production, in fabricating processes where a "predictable" fastening technology is absolutely essential.

Especially when joining aluminium, mechanical fastening methods can meet the increasing demands on joint quality and reproducibility during production and at the same time allow the production quality to be tested using non-destructive methods (**Figure 4101.01.03**). Typical for all mechanical fastening methods is that the joints can be made with none or hardly any heating.

Classification of Mechanical Fastenings Used in the Fabrication Technology

Depending on the joining principle used, a large number of joint designs are possible. As one can see from the systematic of the joining principles, the method of producing the individual joints forms the basis for the classification, with each process having its advantages and disadvantages (see **Figure 4101.01.04**).

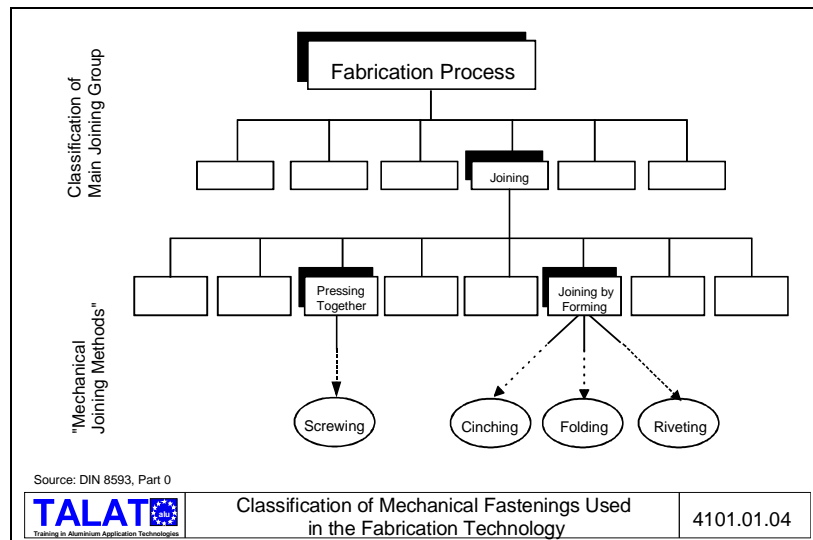
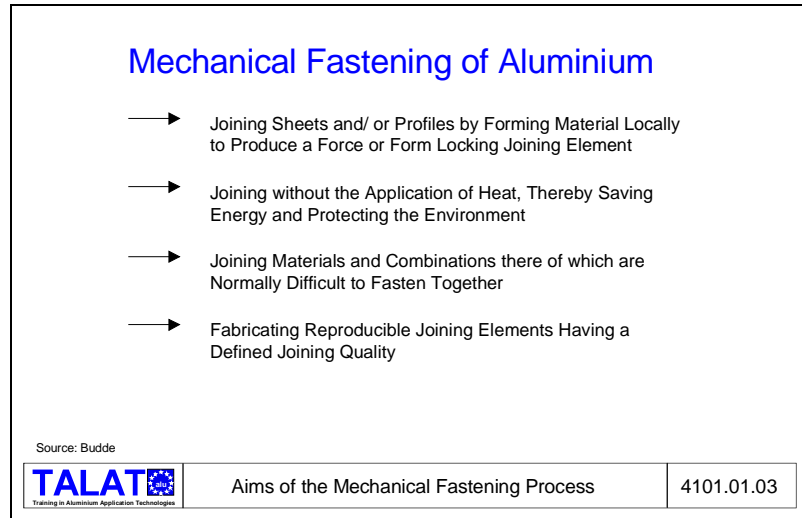

If an aluminium construction has to compete with a steel construction, then it is important to consider the aspects of manufacturing technology, joining techniques and economy. Due to the lower modulus of elasticity, an aluminium component will have a lower rigidity than the corresponding steel component of the same dimensions. Mechanical fastening methods can, however, be used to overcome this shortcoming, at least partly.

Because of their good combinations of properties, the following joining methods have proven to be especially suitable: screwing, clinching, bordering, folding and riveting.

Elementary and Combined Joints

Mechanical fastening methods will not be considered here on the basis of the older viewpoints. They are defined here as joining technologies in which the parts are joint using a force or form locking method like in clinching or riveting. These exclude joints in which there is an (inter)locking of materials as in welding and adhesive joining.

The quasi form locking joint is obtained by a plastic deformation process. Such joints incorporate the advantages of both form locking (transmitting large forces) and the force locking (reducing play) type of joints (**Figure 4101.01.05**).

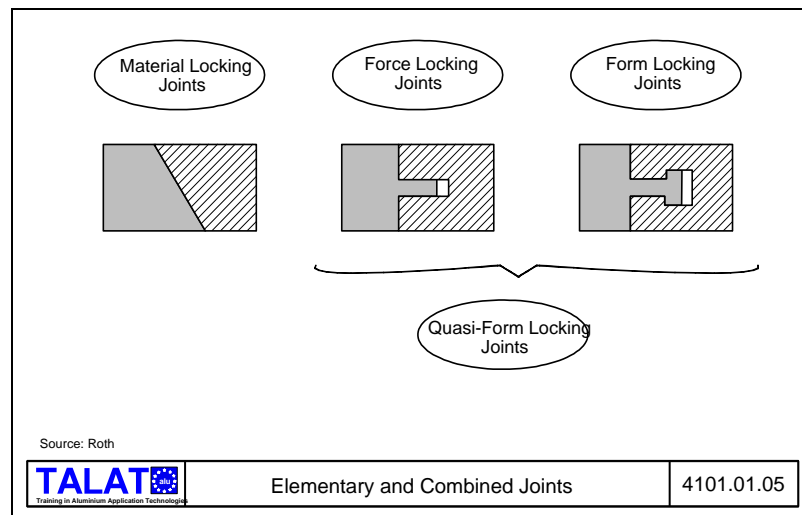

4101.02 Screw Joints

- Construction types for screw joints
- Requirements for screw joints
- Types of screw joints for thin sheets
- Working principle of flow-drilling screws
- Screw joints for aluminium profiles

Construction Types for Screw Joints

Screw joints belong to the group of detachable joints. These can be designed as pierced, through or blind-hole joints (**Figure 4101.02.01**). If appropriate measures are taken against corrosion, screw joints are suitable for shaped sheet components and /or aluminium sections and profiles.

The joining elements should be made of corrosion resistant stainless steel (steel group A2/A4). Since aluminium alloys have relatively lower compressive strengths, the contact surfaces must be protected by using washers under the screw and the nut.

Requirements for Screw Joints

Screw joints consist of multiple elements each of which has to fulfil various requirements at the same time.

In order to design durable, safe and cheap screw joints which fulfil the requirements for different applications, systematically arranged information and other helps must be available.

Application parameters for screw joints can be set up by systematically listing the main requirements for design, calculation and corrosion protection (**Figure 4101.02.02**).

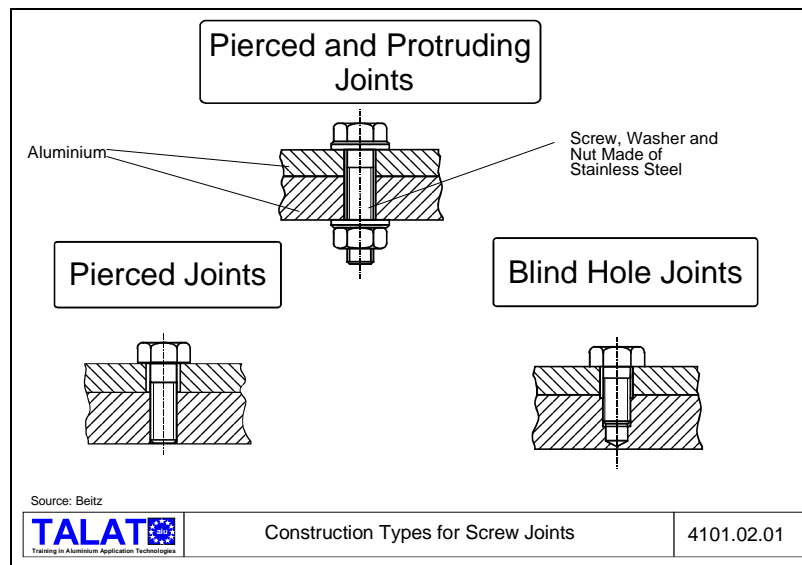

Determining the Main Factors which Influence the Design, Calculation and Corrosion Protection of Screw Joints

1. General Information about the Construction, Fastenings and Parts to be Fastened
2. Assembling Process
3. Mechanical and Chemical Stressing
4. Physical Influencing Factors
5. Life Expectancy - Safety -Reliability
6. Additional Requirements
7. Previous Design and Usable Experience
8. Economy

Source: Sieling



Requirements for Screw Joints

4101.02.02

Types of Screw Joints for Thin Sheets

In addition to the screw-and-nut fastening methods, thin sheets can be joint together using a number of threaded fasteners, the most popular being sheet metal screws of the self-locking, self-tapping types (**Figure 4101.02.03**).

With the help of screw-and-nut fasteners, it is possible to create large clamping forces. Sheet metal screws, on the other hand, are used to eliminate the drilling operation for the final assembly, whereby the screw cuts out its own hole.

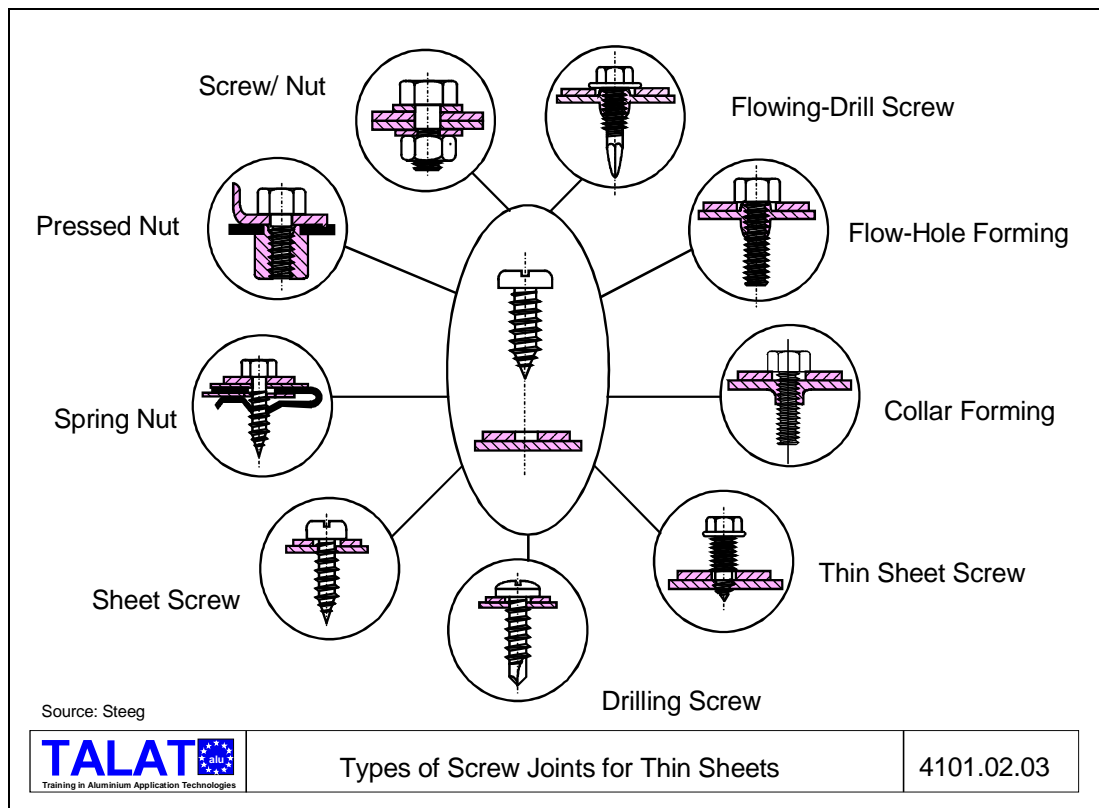

Working Principle of Flow-Drilling Screws

A drawback of most sheet metal screw joint is the very limited load bearing length of the screw. Improvements can be made by forming cylindrical collars during the shaping process.

In the flow-drilling process, a carbide tipped tapered and unthreaded punch rotating at high speed is forced down to pierce through the metal, deforming it plastically and creating a collared hole. A thread can then be tapped in this hole (**Figure 4101.02.04**).

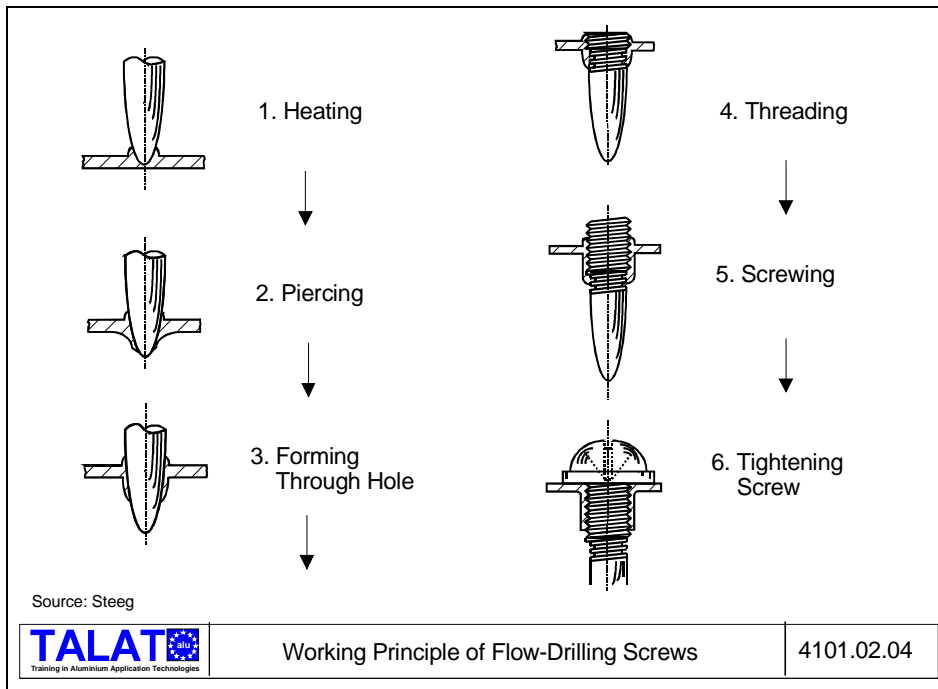

Screw Joints for Aluminium Profiles

Stainless steel sheet metal screws are most often used for joining light metal alloys. Prefabricated profiles are being increasingly used for aluminium constructions. The profiles have longitudinal and transverse screw channels (or grooves) to take up the stainless steel sheet metal screws (**Figure 4101.02.05**).

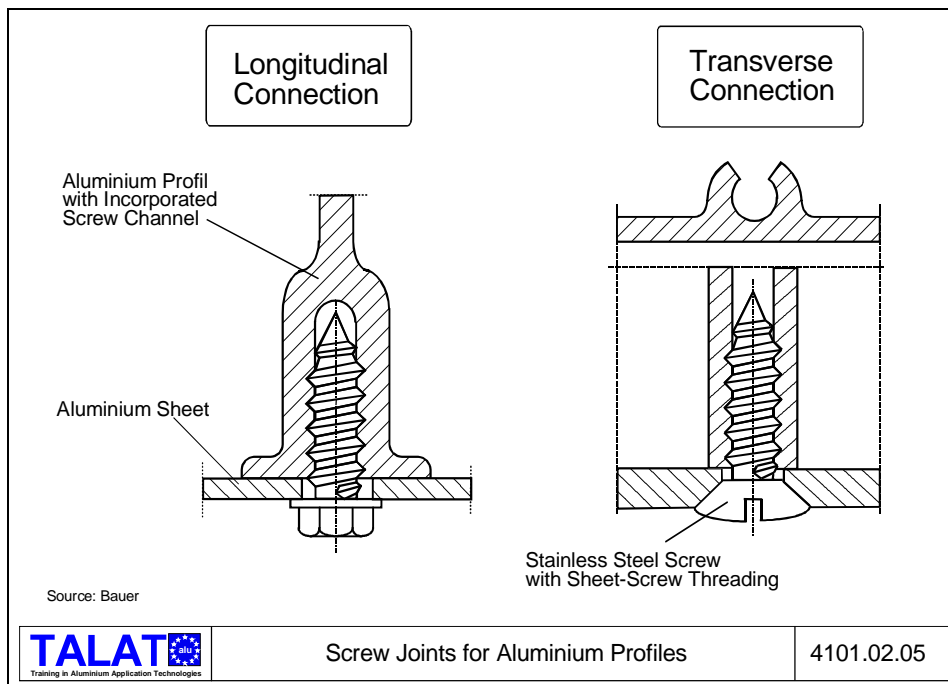

4101.03 Folds

- Steps in the folding process for straight-edged sheets
- Widths of overlaps in folded joints

Steps in the Folding Process for Straight-Edged Sheets

Bordering and folding techniques in a number of variations are traditionally used for joining aluminium effectively.

Form locked joints are created using the following steps: folding manually or automatically, interlocking, pressing together and locking by displacing the sheet edges (**Figure 4101.03.01**).

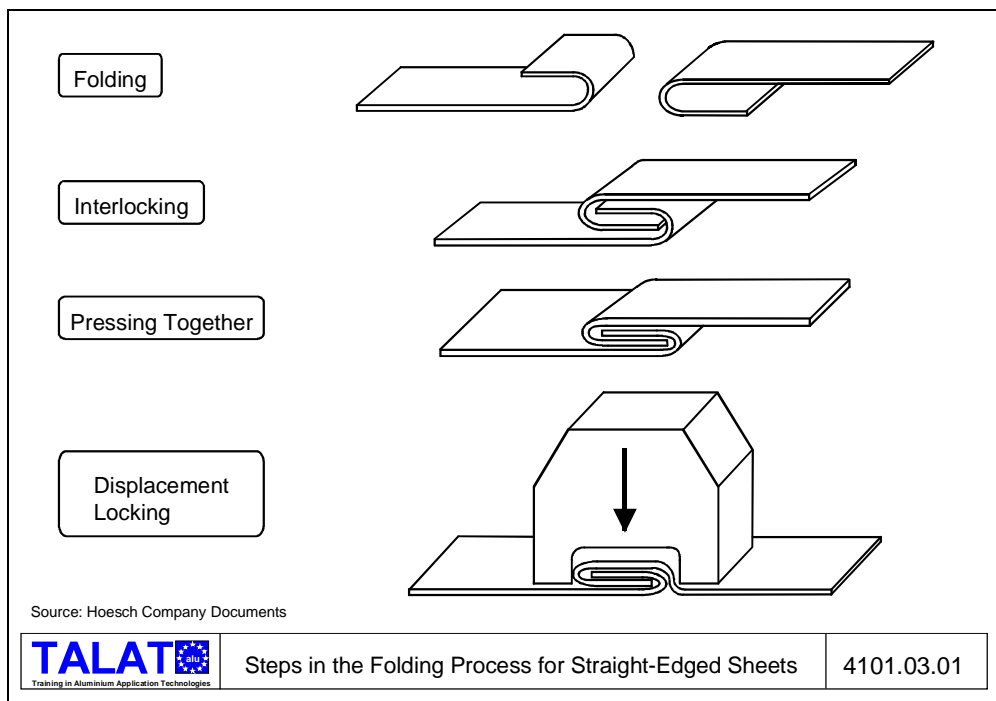

If this fastening method is carried out properly, the protective oxide film is not damaged so that the surface remains protected.

Widths of Overlaps in Folded Joints

Depending on the application, various folding forms can be made, the width of the fold being of special importance for individual parts in handicraft. Whereas narrow folds have low strength and tightness, too large overlaps amount to a waste of material (**Figure 4101.03.02**).

With optimal fold thicknesses, the maximum strength attainable then depends mainly on the fold type as well as quality and thickness of the material.

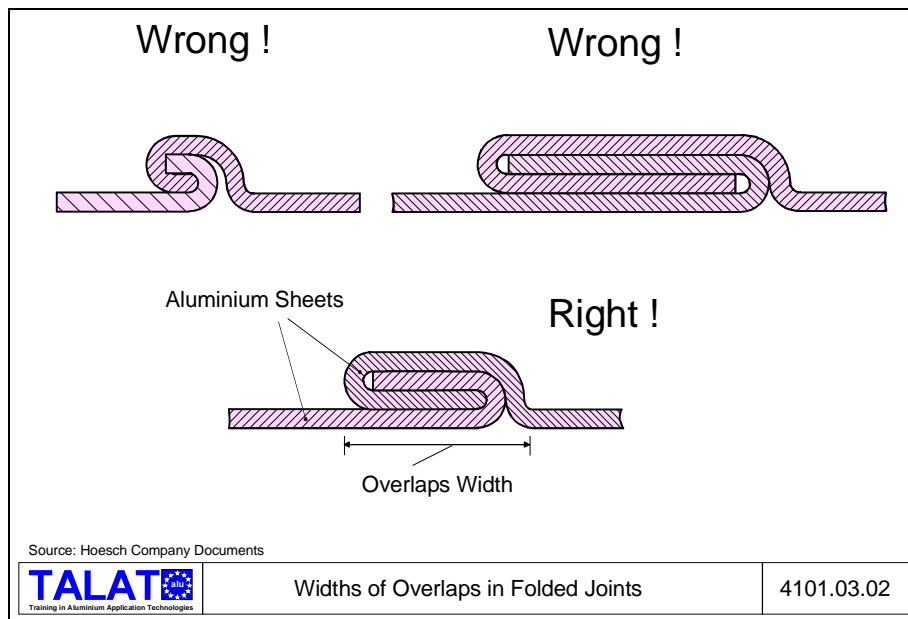

4101.04 Rivet Joints

- Joining by riveting
- Rivet types for the indirect riveting of aluminium
- Commercially available rivet forms and their fields of application
- Working principle of a blind (pop) rivet
- Choice of fastening elements for mechanical fastening methods

Joining by Riveting

For a long period of time, riveting was considered to be outdated and uneconomical. Recently, however, riveting is being rediscovered as a rational technology of high quality especially for special-purpose applications in the aerospace industry.

Aluminium can be joined using the indirect and direct riveting methods (**Figure 4101.04.01**).

In the indirect riveting process the parts to be joined are clamped together with rivets using an auxiliary joining element. In direct riveting, one of the parts to be joint is itself designed to act as the auxiliary component so that a separate one is not necessary.

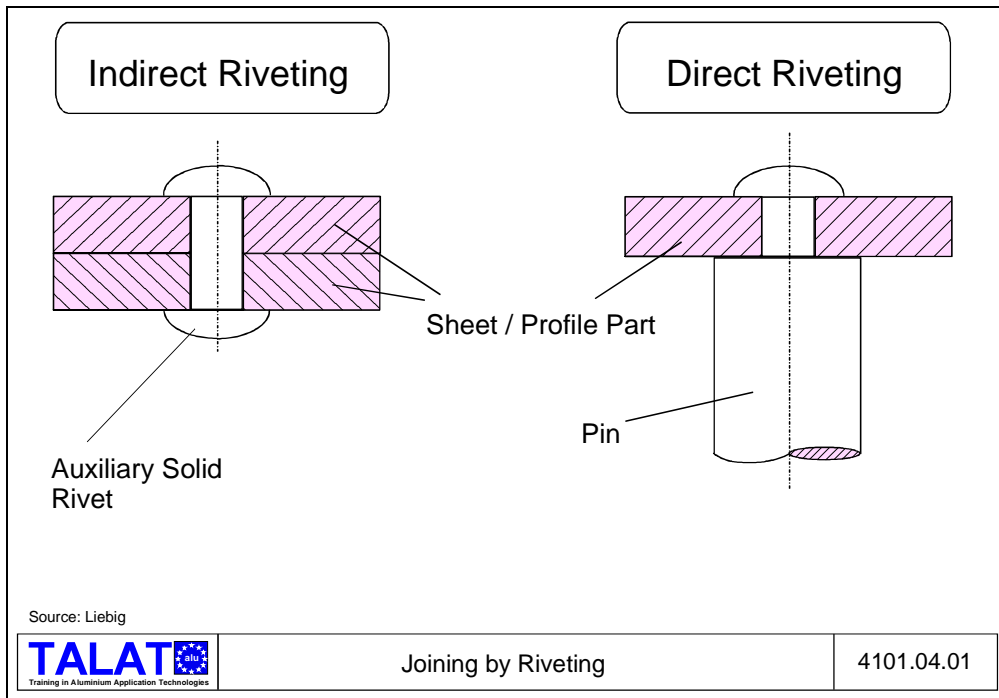

Rivet Types for the Indirect Riveting of Aluminium

Currently, four different types of indirect rivets are used for producing undetachable (permanent) joints: solid rivets, blind (Chobert or pop) rivets, huck bolts (screw rivets) and punch rivets, whereby the rivet groups are classified primarily according to their operational reliability (**Figure 4101.04.02**).

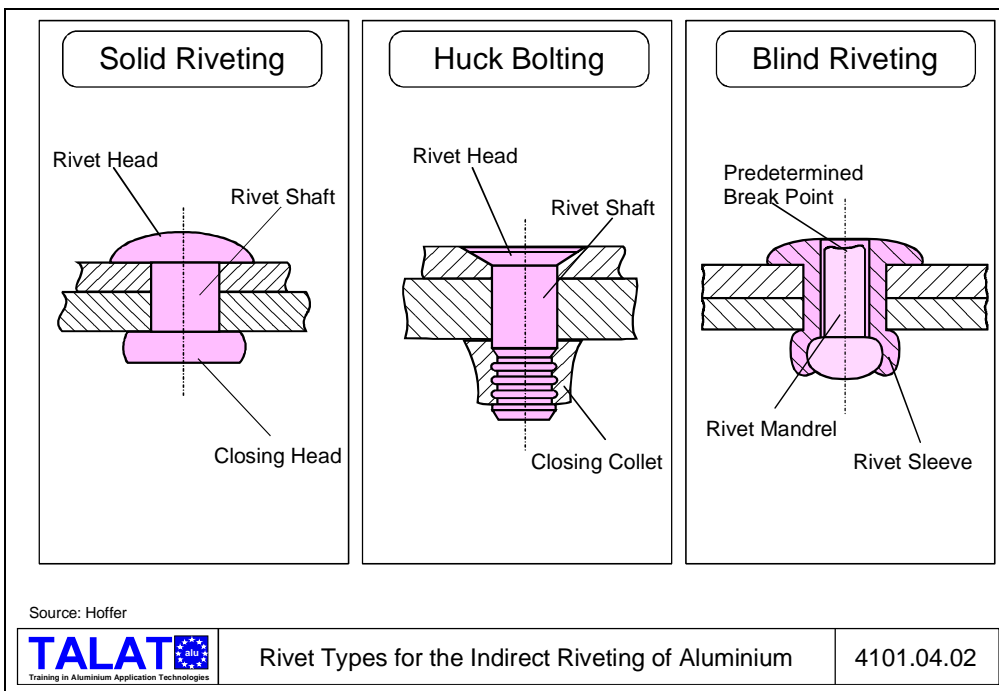

Solid rivets are one-piece joining elements in which the rivet shaft is plastically formed into the closing head. Such rivets can only be used for components which are accessible from both sides.

Huck bolts (screw rivets) are used for highly stressed rivet joints. Since screw rivets are made of high strength materials which cannot be formed easily during assembly, a closing collet (self-locking nut) is fixed on to the rivet.



Blind (Chobert, pop) rivets, including the multi-functional types, consist of one or more elements and require only one accessible side for mounting.

Punch rivets are designed to be self-piercing, making it unnecessary to form holes previously in the parts to be fastened.

Commercially Available Rivet Forms and their Fields of Application

Rivets are classified according to the shape of the rivet head formed during the riveting.

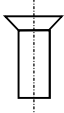
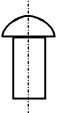
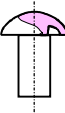
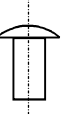
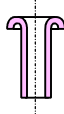
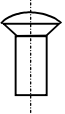
For sheet metal and light constructions which do not need rivets of greater than 8 mm diameter, closing heads with the same form as the rivet heads can be used. Aluminium rivets having a diameter of up to 8 mm can be fairly easily cold worked (**Figure 4101.04.03**).

<p>Countersunk Rivet</p>  <p>For Thick Materials</p>	<p>Halfround Rivet</p>  <p>Generally Used Rivet Head Form</p>	<p>Mushroom Rivet</p>  <p>For Smooth Surface Riveting on the Head Side</p>	
<p>Flat Rivet</p>  <p>For Light Sheet Structures</p>	<p>Tube Rivet</p>  <p>For Cases in Which Only Low Impact Forming Force May be Used</p>	<p>Oval-Headed Countersunk Rivet</p>  <p>For Cases in Which The Protruding Head Should be Small</p>	
<p>Source: Alusingen Company Documents</p>			
	<p>Commercially Available Rivet Forms and Their Fields of Application</p>		<p>4101.04.03</p>

Working Principle of a Blind (Pop) Rivet

Just like many other innovative rivet developments, the blind rivet was developed in the aircraft industry. Generally, blind rivets consist of a hollow shaft and a pull-stem (mandrel) which serves as a tool for forming the closing head.

The rivet is mounted by pulling the stem out with a special tool, whereby the stem head is drawn into the protruding rivet material to form the closing head (**Figure 4101.04.04**). When the pulling force exceeds a certain level, the stem breaks at a predetermined position (notched or break-stem). The breaking point can be chosen to lie either in the shaft or at the rivet head.

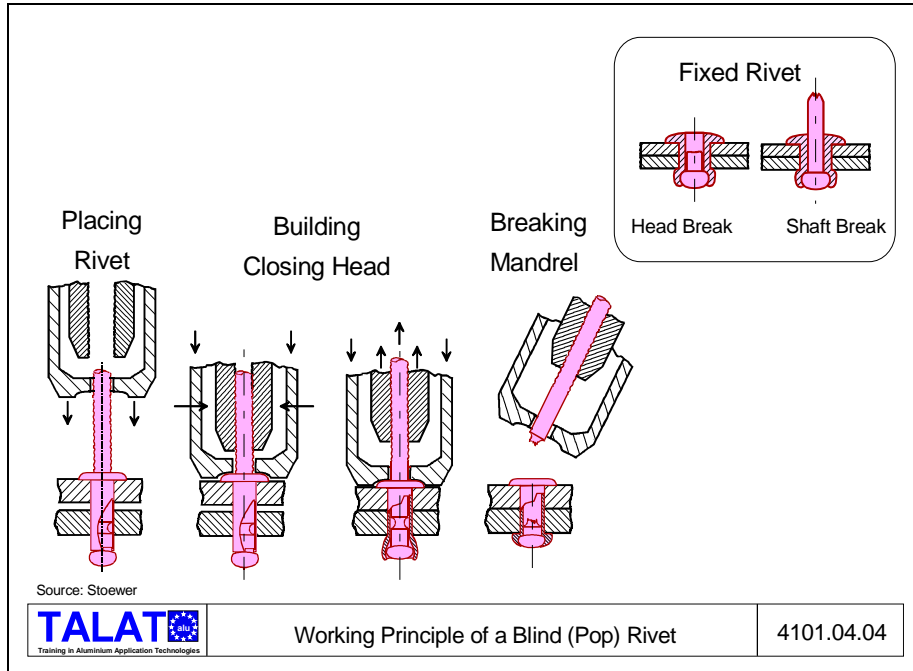

Choice of Fastening Elements for Mechanical Fastening Methods

Mechanical fasteners using auxiliary fastening elements should be chosen so that both fastener and the components to be joint are compatible as far as corrosion and recycling aspects are concerned. It follows that the parts which come in contact with each other must have similar electrochemical potentials and the material combination used must be tolerant with respect to recycling (**Figure 4101.04.05**).

Choice of Material for Joining Elements for the Mechanical Fastening of Aluminium Constructions		
→	Because of reasons of corrosion, parts which come into contact with each other should have similar electrochemical potentials.	
→	Because of reasons of recycling, the materials of the parts involved should be compatible.	
	Choice of Fastening Elements for Mechanical Fastening Methods	4101.04.05

Fastening elements made of copper or brass are not suitable for joining aluminium parts. In an environment where the joints are subjected to weathering or chemical attack, the parts must be isolated from the fastening elements, both for aluminium parts of different alloys as well as for composite constructions.

4101.05 Clinching

- Schematic illustration of clinching joints, with or without local incision
- An aluminium car door aggregate carrier with clinch joints

Schematic Illustration of Clinching Joints, with or without Local Incision

Although clinching is now widely accepted and used as a "new" process for fastening aluminium shaped sheet components and profile components as undetachable (permanent) joints, the rules and guidelines governing this type of fastening method have still to be defined.

Clinching covers processes for direct joining in which the material undergoes a local plastic deformation with or without local incision (**Figure 4101.05.01**).

The term clinching covers various processes known more popularly by their trade names.

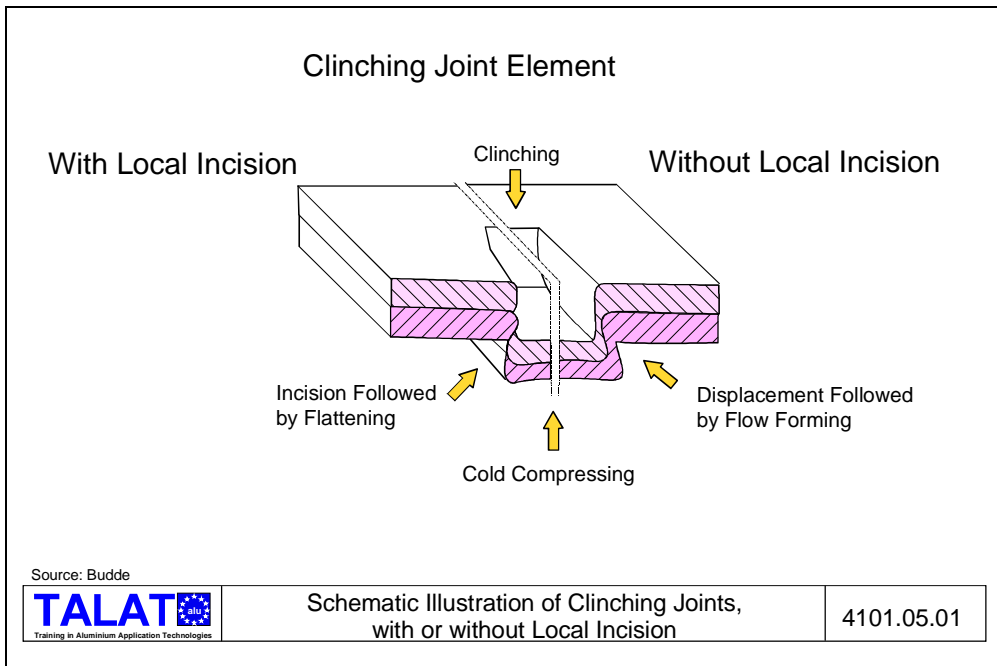

An Aluminium Car Door Aggregate Carrier with Clinch Joints

The technology for fastening methods based on clinching and the "newer" riveting processes is being developed continuously, so that an ever increasing use of these joining methods can be safely expected in the years to come.

Presently, the most well known example for a mass produced component using the clinching fastening method is the door aggregate carrier for the AUDI 80/90 in which two aluminium sheet forms are clinched together (**Figure 4101.05.02**).

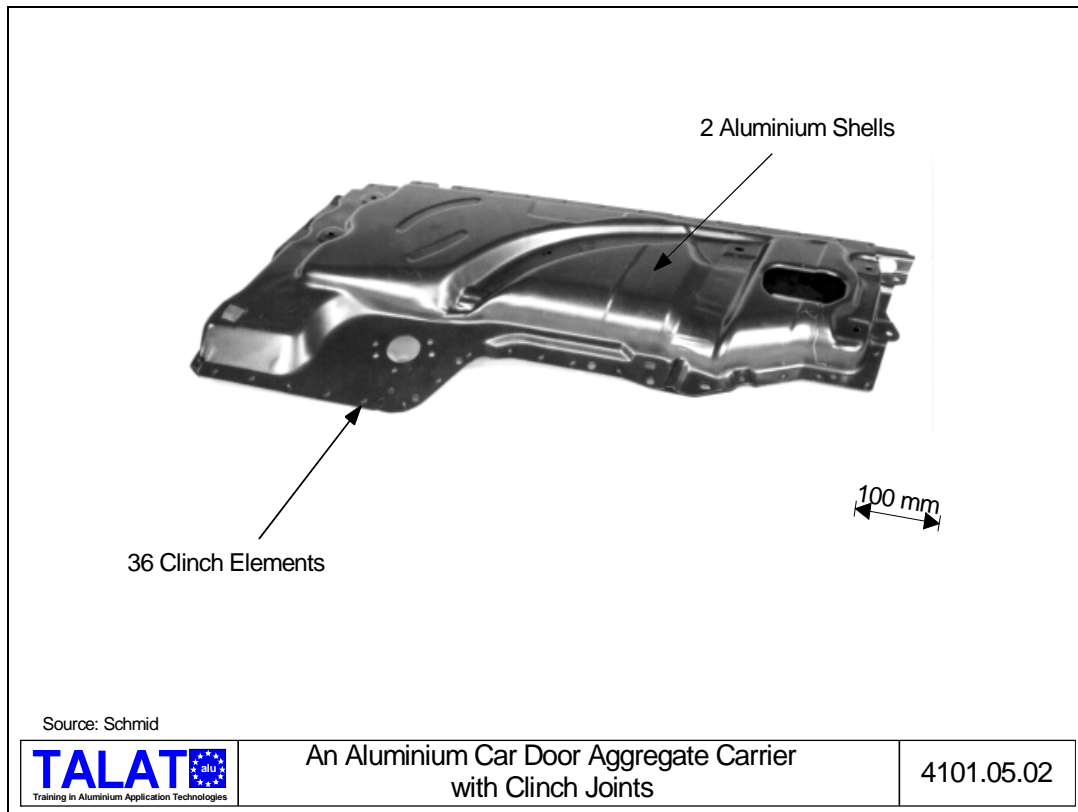

4101.06 Summary

- Comparison of the technological characteristics of fastening methods

Comparison of the Technological Characteristics of Fastening Methods

Riveting and clinching are typical examples for mechanical fastening methods.

The above mentioned fastening methods are most promising since, compared to the "conventional" fastening methods, these are easier to use, have shorter pressing times and the parts to be joint are subjected to a lower heat stress (**Figure 4101.06.01**).

Comparison of the Technological Characteristics of Fastening Methods

Joining Technology Characteristic	Adhesive Joining	Spot Welding	Cinching	Riveting
Technology Process parameters	very complicated	complicated	limited	limited
- time	short to long	very short	very short	short to long
- temperature	relatively low	very high	very low	very low
- pressure	low to high	relatively high	relatively high	relatively high

Source: Budde



Comparison of the Technological Characteristics
of Fastening Methods

4101.06.01

4101.07 Literature/References

1. **Bahre, R.** Verbindungstechnik für dünne Bauteile. Technica 35 (1986) 10, 61-66
2. **Singh, S.** Fügen von Aluminiumwerkstoffen im Automobilbau. Ingenieur-Werkstoffe 2 (1991) 3, 45-48
3. **Budde, L.** Untersuchungen zur Kombination quasi-formschlüssiger und stoffschlüssiger Verbindungsverfahren. Dissertation Uni-GH-Paderborn, 1989
4. **N.N.** Fertigungsverfahren Fügen; Einordnung, Unterteilung, Begriffe. DIN 8593, Teil 0.
5. **Klein, B.** Fügetechnologien des Maschinenbaus. Der Konstrukteur (1986) 11, 6-14
6. **Roth, K.** Systematik fester Verbindungen als Grundlage für ihre sinnvolle Anwendung und Weiterentwicklung. VDI-Berichte Nr. 360, 7-19
7. **Beitz, W.** Generelle Gestaltungsempfehlungen für Schraubenverbindungen. VDI-Z 125 (1983) 6, 257-263

8. **Sieling, P.** Drehschlagbetätigte Einsatzwerkzeuge. Verbindungstechnik (1977) 7/8, 13-24
9. **Stegg, H.B.** Rationalisierungspotential Dünnschleibverschraubung. VDI-Berichte Nr. 883, 215-239
10. **Bauer, C.O.** Wege zu sicheren und wirtschaftlichen Schraubenverbindungen. VDI-Z 124 (1982) 18, 67-76
11. **Liebig, H.P.** Nieten und Durchsetzfugen. Blech Rohre Profile 39 (1992) 3, 220-221
12. **Hoffer, K.** Systemoptimierte Verbindungen im Flugzeugbau. VDI-Berichte 360, 31-43

4101.08 List of Figures

Figure No.	Figure Title (Overhead)
4101.01.01	Tendency of Developments in the Joining Technology
4101.01.02	Joining Systems for Thin-Walled Aluminium Components
4101.01.03	Aims of the Mechanical Fastening Process
4101.01.04	Classification of Mechanical Fastenings Used in the Fabrication Technology
4101.01.05	Elementary and Combined Joints
4101.02.01	Construction Types for Screw Joints
4101.02.02	Requirements for Screw Joints
4101.02.03	Types of Screw Joints for Thin Sheets
4101.02.04	Working Principle of Flow-Drilling Screws
4101.02.05	Screw Joints for Aluminium Profiles
4101.03.01	Steps in the Folding Process for Straight-Edged Sheets
4101.03.02	Widths of Overlaps in Folded Joints
4101.04.01	Joining by Riveting
4101.04.02	Rivet Types for the Indirect Riveting of Aluminium
4101.04.03	Commercially Available Rivet Forms and their Fields of Application
4101.04.04	Working Principle of a Blind (Pop) Rivet
4101.04.05	Choice of Fastening Elements for Mechanical Fastening Methods
4101.05.01	Schematic Illustration of Clinching Joints, with or without Local Incision
4101.05.02	An Aluminium Car Door Aggregate Carrier with Clinch Joints
4101.06.01	Comparison of the Technological Characteristics of Fastening Methods