

TALAT Lecture 2110.01

Automobile Brake Rotor - LCA in Product Design

31 pages, 26 figures

Advanced Level

prepared by Sigurd Støren and Tor Bækkelund, The Norwegian Institute of Technology, Trondheim

This lecture offers an example of product development in a life cycle perspective

Objectives:

to impart knowledge about

- production and casting of SiC-particle reinforced aluminium metal matrix composite - PMMC (SiCA17SiMg)
- use of Life Cycle Analysis

to provide insight to

- how to redesign a product using life cycle thinking and LCA to minimize the ecological side effects.
- the importance of having a thoroughly knowledge about the product's life and its environmental impact.

Prerequisites:

- to know the concept of the product information structure - "the chromosomes"
- to be familiar with LCA methodology

Date of Issue: 1994

© EAA - European Aluminium Association

2110.01 Automobile Brake Rotor - LCA in Product Design

Table of content

| | |
|---|----|
| 2110.01 Automobile Brake Rotor - LCA in Product Design | 2 |
| The Automobile - Environmental Demands | 3 |
| The Automobile Brake System | 3 |
| The Product Topological Structures | 4 |
| The Wheel Design..... | 6 |
| The Brake Rotor..... | 7 |
| <i>The Calliper</i> | 7 |
| <i>The Rotor</i> | 7 |
| Basic Specifications | 8 |
| <i>Functions</i> | 8 |
| <i>Requirements</i> | 9 |
| <i>Properties</i> | 9 |
| <i>Material Properties</i> | 11 |
| Possible Solutions | 12 |
| <i>Materials, Functional and Environmental Performance</i> | 12 |
| Particle Reinforced Aluminium - PMMC (Special Study) | 13 |
| <i>Production of PMMC</i> | 14 |
| <i>Characteristics of the PMMC Production and Casting Process</i> | 15 |
| <i>Casting Methods for the PMMC</i> | 17 |
| Life Cycle Analysis..... | 18 |
| <i>Life Cycle Logistics</i> | 19 |
| <i>Life Cycle Analysis</i> | 21 |
| Comparison | 22 |
| <i>Energy Consumption</i> | 22 |
| <i>Material consumption</i> | 23 |
| <i>Reliability and Safety</i> | 23 |
| <i>Life Cycle Cost</i> | 23 |
| <i>Pollution</i> | 24 |
| <i>Concluding LCA Remarks</i> | 27 |
| Material properties | 27 |
| Conclusion | 29 |
| References..... | 30 |
| List of Figures | 31 |

The Automobile - Environmental Demands

The growing environmental consciousness among consumers and public administration have resulted in increased focus on life cycle thinking and improvements of environmental performance. The automobile is a major source to pollution and has been widely debated during the last decade. The automobile as a technical system or product holds a variety of qualities, which indirectly dictates the environmental impacts through its production, assembly, use, reuse, repair, disassembly and scraping. The mechanical systems in the automobile are mainly the engine, the power transmission, the brake system and the body structure.

This example illustrates the development and redesign of a brake rotor in the context of improved environmental performance. It is presently a research project and we have to assume a number for the units produced. We also assume to operate as a supplier to the automobile industry.

The world production of new automobiles is 35 million a year ¹⁰⁾. If one considers that each automobile has brake rotors on the front wheels the world annual production of brake rotors are approximately 70 million a year. Cast iron brake rotors of 4,5 kg indicates at least an annual production of 315 000 tonnes cast iron brake rotors besides the production needed for the remaining drum brakes.

The Automobile Brake System

In addition to attain better economy and ecology, the general striving for comprehensive safety is one of the central concerns of automotive engineering. As a consequence, the vehicle components which are relevant in terms of active and passive safety, are subjected to continuous optimization. Significant higher demands have been made on the braking system during the past years as a result of increased engine power output, average speed and gross vehicle weight rating (vans, trucks etc.) and reduced air drag and rolling resistance of the tyre ¹⁾.

The brake system components in the wheel system is non-dampened mass. The brake rotor is non-dampened rotating mass and will, if reduced, reduce the environmental impact from the use of the automobile. Most cars have front brake rotors (**Figure 2110.01.01**).

The Automobile Brake Rotor

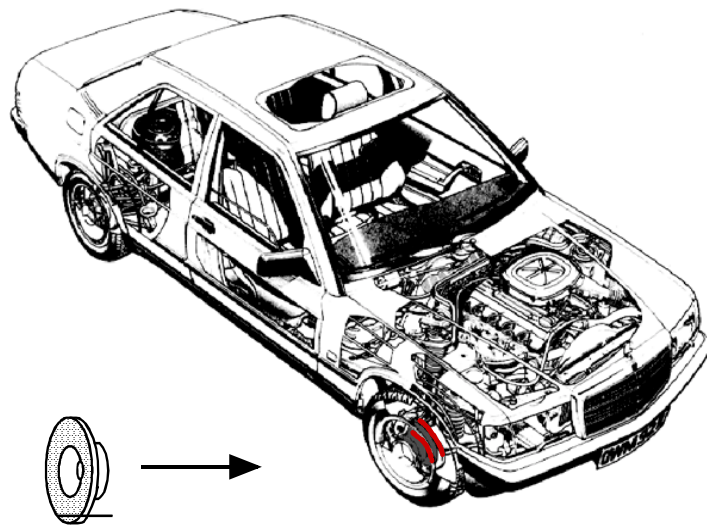

The Product Topological Structures

To obtain a complete knowledge about where and when competitiveness is located in the production and use of the brake rotor, it is practical to use the chromosomes as a basis. A life cycle analysis combined with the chromosomes will provide necessary data about environmental and functional performance besides information about the production of the brake rotor.

In this example we will first look at the wheel design and the basic properties, so that we have a good basis for selecting the best solution. Next we will analyse the life cycle to expose the environmental performance.

Using the theory of domains and the topological structure on the braking system we can start with the process to **reduce the speed of the automobile** as a part of the total product process moving goods or people. A controllable reduction of speed is realised by the **transfer of braking power** from the hydraulic system through the wheel into the ground. The **calliper and the brake rotor** are a part of the wheel system. They constitute an organ, which primarily is characterised by its ability to create friction. The calliper and the brake rotor are produced by suppliers and are delivered ready for **assembly**. The **process units** that characterise the organ are the **cleaning and machining** of the rotor in addition to the pad and rotor material properties.

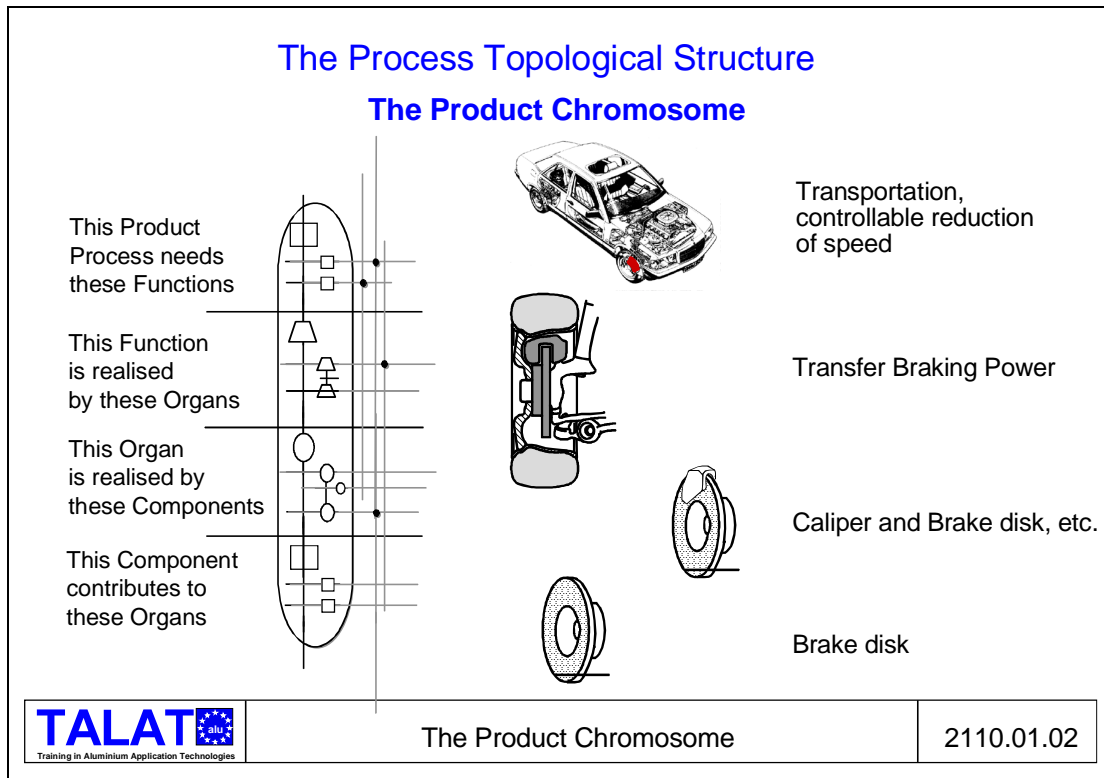

The product and process chromosomes are illustrated in **Figure 2110.01.02** and in **Figure 2110.01.03**.

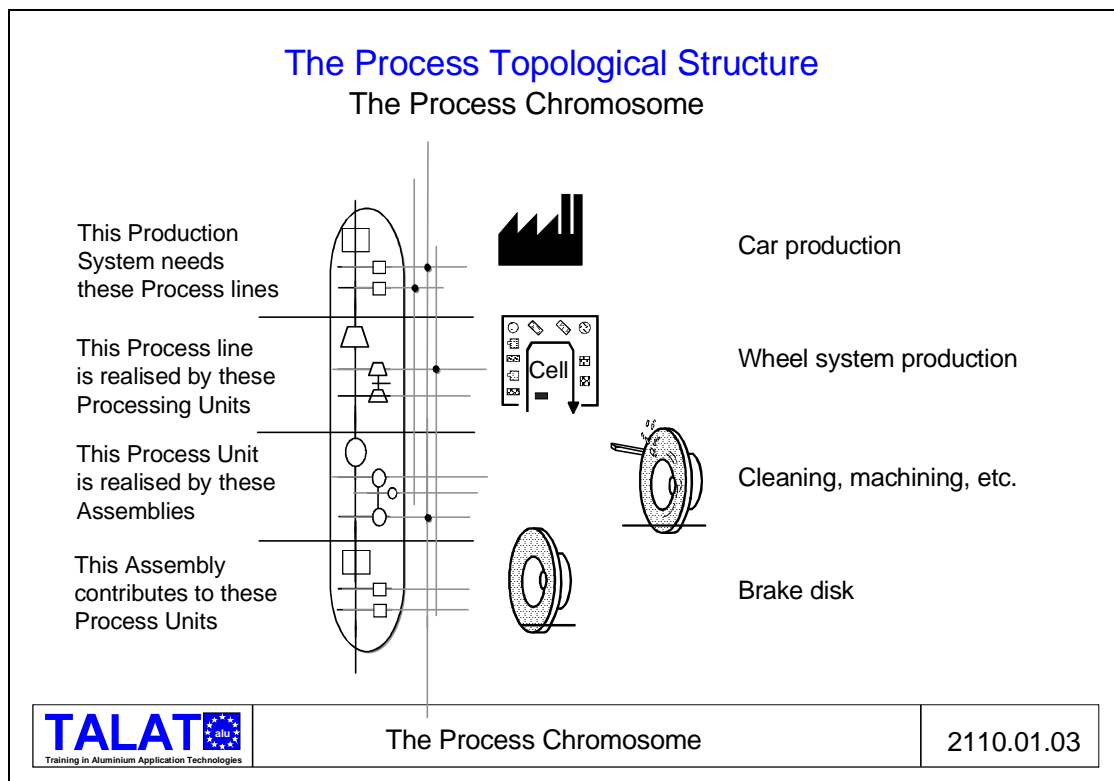

The Wheel Design

Before we specify which functions, requirements and properties a brake rotor must satisfy or hold, we will look at the wheel design and the technical systems.

The wheel rim is specified by the carmakers and is one of the first constraints which is set. The size of the wheel (height and width) is closely related to the kind of car it is build for²⁾. Different wheel designs give different qualities to the wheel and the car as a whole. The rim dictates the available space for the parts that must be inside (**Figure 2110.01.04**). When optimizing the wheel design several design criteria have to be considered. The internal systems in addition to the brake system are: the steering system (front), the suspensions, the stabilisers, the driveshafts (front/rear or both), the calliper and the knuckle assembly (the node which connects the specified systems to each other). **Figure 2110.01.05** illustrates their placement in the wheel design. These systems vary with different car designs and car makers.

The optimization of the brake system is dependent of the wheel size (height and width) and vice versa. Increased height (h) increases the rotor radius and space for the internal systems. Increased width (w) increases also the space for the internal systems. The rim design also dictates the placement and design of the calliper. The calliper dictates the placement of the rotor and the rest of the systems connected to the rotor. The wheel is a multifunctional technical system. Our example will only consider the brake system.

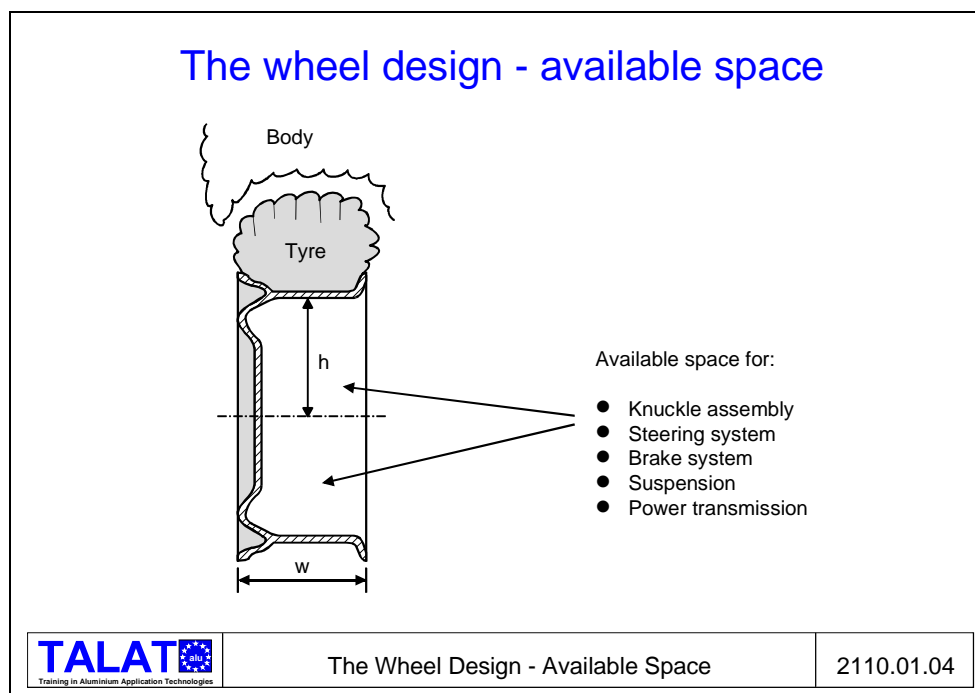

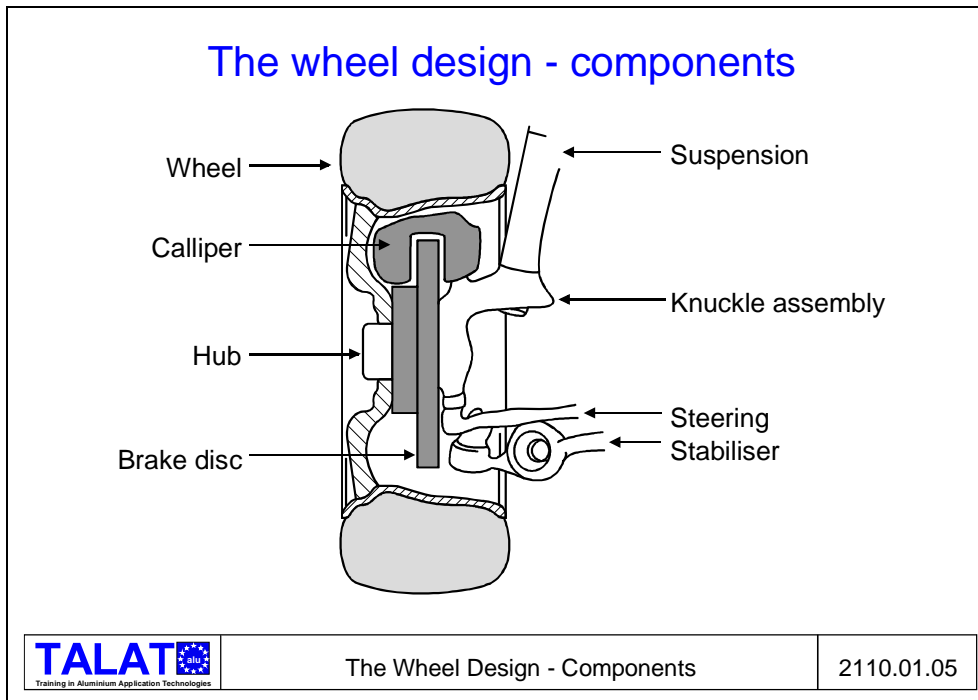

The Brake Rotor

The rotor and the calliper organ is a "meetingplace or interaction between surfaces" and its functional quality contributes to the consumers' perception of the automobile performance. The environmental performance is linked to the production, assembly, use, reuse, repair, disassembly and scraping.

The Calliper

The calliper system transfers kinetic energy (hydraulic pressure) to heat by friction between the rotor pads and the rotor. The main parts of the calliper are the piston, the rotor pads and the calliper body. The piston presses the rotor pads towards the rotor as a result of increased hydraulic pressure. The size of the rotor pads varies, but it is the pressure over the wear surface plus the wear material which determines the friction ²⁾. The calliper body is a saddle that holds the calliper components and fastens the calliper to the knuckle assembly.

The Rotor

There exist different brake rotor designs: Ventilated and solid brake rotors. The ventilated rotor concept was invented because of cooling problems . The characteristic

functional surfaces of the rotor are: the wear surface, the surface for fastening and the cooling surface (**Figure 2110.01.06**). The design, the surface and the material determine the brake rotor properties. The surface and the materials determine the friction properties.

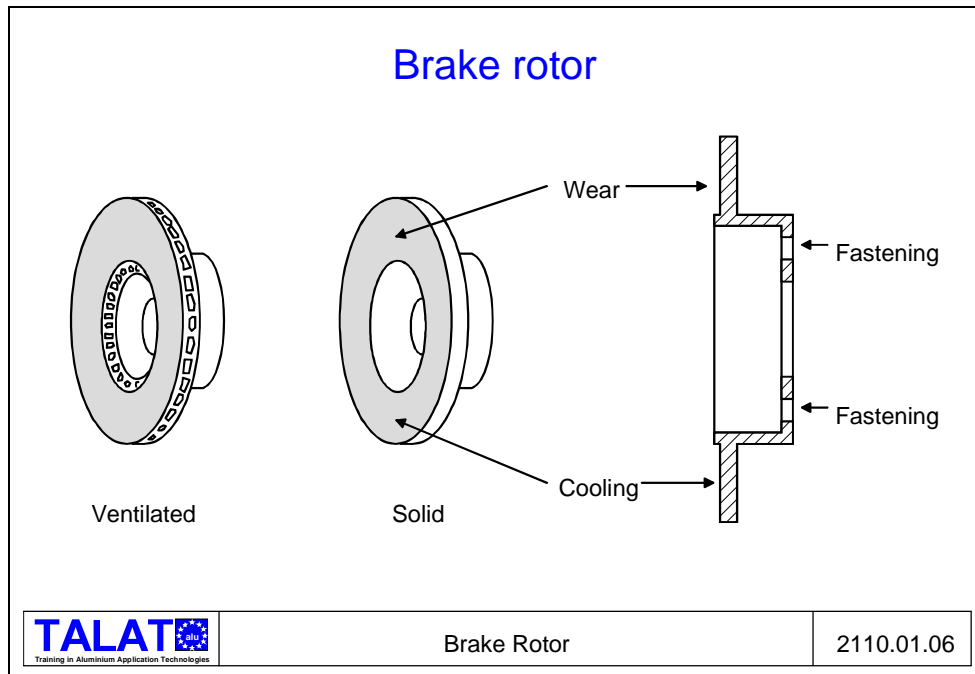

Basic Specifications

We are now able to define the specifications. Due to the complexity of the car and the wheel design, only the most important aspects related to the rotor will be considered in this example.

Functions

The main functional requirement for the brake system is "to provide a controllable reduction of speed". The following function applies to the brake rotor (**Figure 2110.01.07**):

Transmit braking power: The primary function is that the brake rotor is able to transmit power from the calliper to the rim.

Function and Requirements

- **Function**

- Transmit braking power

- **Requirements**

- Withstand stress
- Ample space must be provided for steering, suspension, knuckle assembly, stabilisator and driveshaft (front wheel drive)
- Working temperature
- Recycling possible
- Design tolerances must coincide with other tolerances
- Satisfy test requirements



Function and Requirements

2110.01.07

Requirements

Certain requirements apply to the construction of this component (**Figure 2110.01.07**) because it is a part of a larger structure:

Withstand stress: It must be capable of withstanding the dynamic stress and strain caused by retardation, steering and rough road.

Ample space must be provided for the steering (front), the suspensions, the stabilisers, the driveshafts, the calliper and the knuckle assembly. The brake rotor has to be adapted to the dimensions and tolerances that apply.

The rotor must satisfy the test requirements for the retardation of the vehicle (requirements from the authority), lifetime, reliability and safety requirements made by the car makers.

The **working temperature** must be under the melting temperature for the specified material.

Recycling possible: The material selected must be recyclable.

The **design tolerances** must coincide with the rest of the wheel parts.

Properties

The properties that denote a good brake rotor solution are the following (**Figure 2110.01.08**):

Low noise level: Comfort is a key competitive parameter in the automobile industry. Noise as a result of braking is a comfort parameter that is undesirable by automobile owners.

Low life cycle cost: The cost accounting in a life cycle perspective should be low for customer, company and society.

Low pollution rates in production, assembly, during use of the automobile, disassembly and in reprocessing of the brake rotor.

Low energy consumption: Energy consumption in processing, use, reuse and recycling must be low.

Low material consumption.

Provide safety and reliability: The rotor design must provide safe and reliable braking in its entire life. All interdependent processes in manufacturing and remanufacturing should not be linked to unsafety and unreliability.

High serviceability is synonymous to easy changing of parts. It can be either the rotor pads or the rotor itself.

Properties of the brake rotor

- Low noise level
- Low life cycle cost
- Low pollution rates
- Low energy consumption
- Low material consumption
- Provide safety & reliability
- High serviceability

| <h2 style="color: blue;">Material properties</h2> | | |
|--|---------------------|------------|
| <ul style="list-style-type: none"> ● Provide homogenous friction coefficient ● Low density ● High corrosion resistance ● High modulus of elasticity ● High wear resistance ● High heat conductivity ● Low thermal expansion coefficient ● High specific strength | | |
|  | Material Properties | 2110.01.09 |

Material Properties

(Figure 2106.01.09)

The contact surface between the pads and the rotor must give a **homogenous friction coefficient**.

Low weight. Reduction of weight is important due to the use of the automobile.

High corrosion resistance: The material must withstand the working environment.

High modulus of elasticity.

High wear resistance: The rotor must hold high wear resistance independently of the solution. This is also dependent on the rotor pad material.

High thermal conductivity: The energy that develops during retardation must be transmitted to the surrounding air. The material must have a high heat conductivity to avoid overheating and brakedown. Design can also improve the cooling.

Low thermal expansion coefficient: Due to working temperature, which is also determined by the heat conductivity, the expansion coefficient must be low.

The brake rotor must have a **high specific strength**, so that no lasting deformations occur.

Not all properties operate at the same level or are equally important. For our purpose, redesigning a component, we will give priority to the environmental performance, the material properties and functional characteristics. This is due to the importance of the

material selection and its interdependence with the environmental performance besides the characteristics of the case.

Possible Solutions

The specifications mainly involve material properties and environmental parameters. The existing brake concepts are made of cast iron and this example considers a brake rotor with a determined design. It is, therefore, logical to begin by considering alternative materials.

Materials, Functional and Environmental Performance

At first, a qualitative evaluation of possible materials can be done to determine which material is best suited for the product. We will try to choose a material which can be used by both designs. Casting is the best option for the rotor production process and the following materials lend themselves well to casting:

- Iron
- Aluminium
- Particle reinforced aluminium
- Magnesium
- Titanium

At this stage in the development process we will attempt to evaluate the various metals without an in-depth study. The table below lists important requirements and properties and attempts to evaluate the various material options against each other (see **Figure 2110.01.10**).

Possible materials

| Properties Materials | Weight | Recyclable | Wear | Dynamic Strength |
|-------------------------|--------|------------|------|------------------|
| Cast iron | -- | + | + | ++ |
| Aluminium | ++ | ++ | -- | + |
| PMMC | ++ | + | ++ | ++ |
| Magnesium | ++ | + | -- | + |
| Titanium | ++ | + | -- | ++ |

The material selection process is complex and we will at this phase qualitatively select two solutions for further analysis. As we can see the PMMC-material seems to be a good alternative to the existing solution of cast iron. Neither aluminium, magnesium nor titanium are possible solutions due to low wear resistance.

Our next step is to analyse and describe the life cycle of the cast iron and the particle reinforced aluminium brake rotors. At first we will describe the production processes, evaluate the critical parameters in the life cycle and then discuss the material properties of the two solutions.

Particle Reinforced Aluminium - PMMC (Special Study)

Particle reinforced aluminium matrix composite is a mixture of aluminium alloy and silicium particles. The particles are mixed with the aluminium and provide the reinforcement of the metal alloy. The microstructure of the SiC reinforced aluminium alloy AlSi7Mg0.6 is illustrated in **Figure 2110.01.11**.

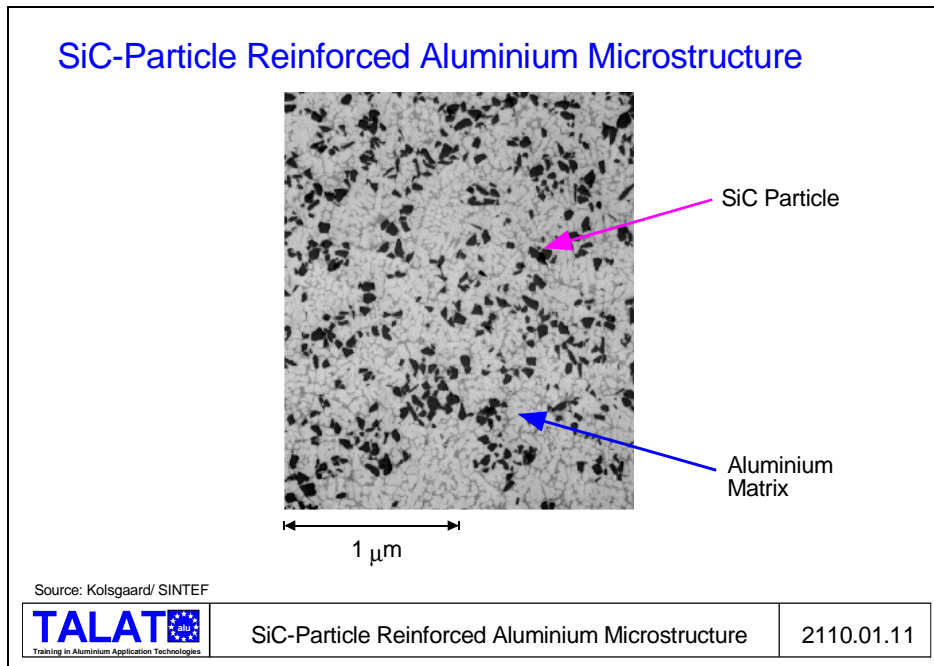

Before we go any further selecting material and alloy it is important to be familiar with the fabrication process and the life cycle logistics of the PMMC and the cast iron brake. Then we can select the material with the best environmental performance. This calls for expert advice to exploit the possibilities and limitations inherent in the fabrication of the composite.

Foundries and metal producers can usually provide the necessary data and information about the process and assist in the design and material selection process.

Production of PMMC

The matrix composite material production starts with the production of the aluminium alloy AlSi7Mg and the silicon carbide particles. The aluminium is moulded into barrels and silicon particles are made out of crude, which is produced from coke and sand. The SiC-particles have a diameter between 10 and 20 µm. The aluminium and the particles are then mixed to a composite melt which is constantly stirred, so that the particles are uniformly distributed within the melt. This is necessary because of the weight of the particles. The volume percentage SiC-particles are from 10 to 20 dependent on the material properties, further production and use of the end product.

The composite melt are then cast into ingots for further processing. The weight of the ingots is 10 - 15 kg. The composite melt can also be made to DC-billets for extrusion processes. The ingots are melted in an induction furnace before casting. The production process of PMMC is illustrated in **Figure 2110.01.12**.

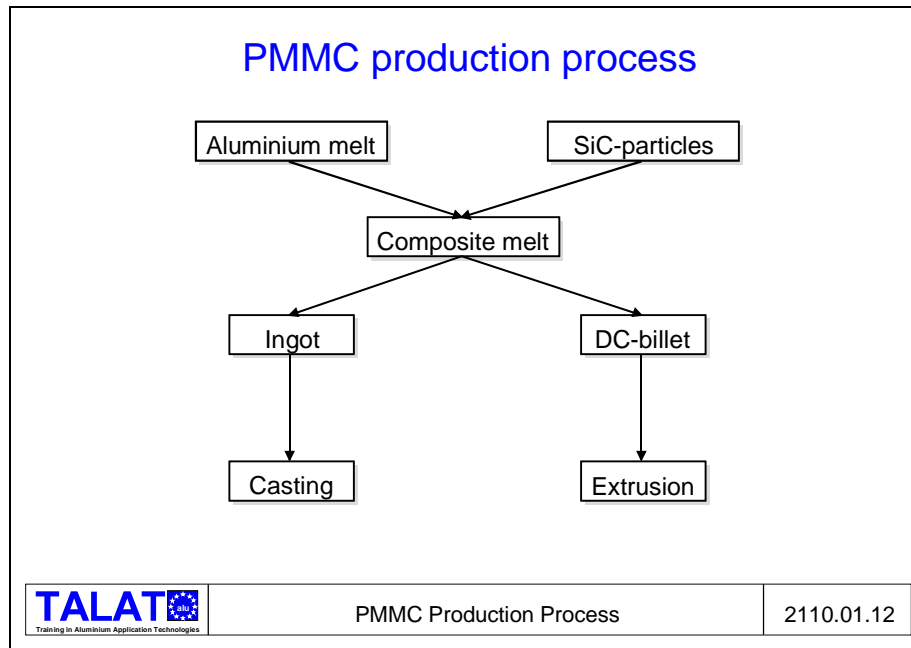

Characteristics of the PMMC Production and Casting Process

A good end product or component is determined by different production parameters for the PMMC material production and casting process.

The most important PMMC material production parameters are: particle incorporation (wetting), particle distribution, temperature control and particle settling. The particles must be incorporated in the melt so that no lumps occur and that the particle distribution gets uniform. The wetting of the particles preserves a uniform distribution. A uniform distribution also demands constant stirring of the melt during holding and before pouring. This is particularly important when the matrix contains small amounts of large SiC particles when the settling rate is large. The chemical reaction between the AlSi7Mg alloy matrix and the SiC particles limits the feasible working temperature. The maximum processing and working temperature of the composite is 800 °C.

During casting of products demanding uniform particle distribution, it is important to be able to separate between the 4 different contributions to a non-uniform particle distribution: settling, solidification rate, flow length and grain size, in order to control the production process and reduce process variations. The solidification conditions largely influence the particle distribution in a casting, and the choice of casting method is dependent of this relation. Short solidification time gives the best particle distribution, and if uniform particle distribution is demanded the choice of casting method is limited to permanent mould casting processes. The settling rate is also dependent on the choice of casting method, and, for instance, with high pressure die-casting, the particle settling during mould filling is almost negligible. The solidification rate and the grain size both

influence the particle distribution simultaneously during solidification of a PMMC product. The grain size can only be controlled during casting using a grain refiner (e.g. ceramic filter). During casting a high flow rate will create bubbles or pores and due to the particles ability to hold these pores an arrangement is necessary to separate them from the melt. A choke and a bubble trap may be used to avoid pores. The pores are also created during incorporating of the SiC particles in the PMMC production process. **Figure 2110.01.13** illustrates an aluminium and a composite mould casting arrangement, respectively.

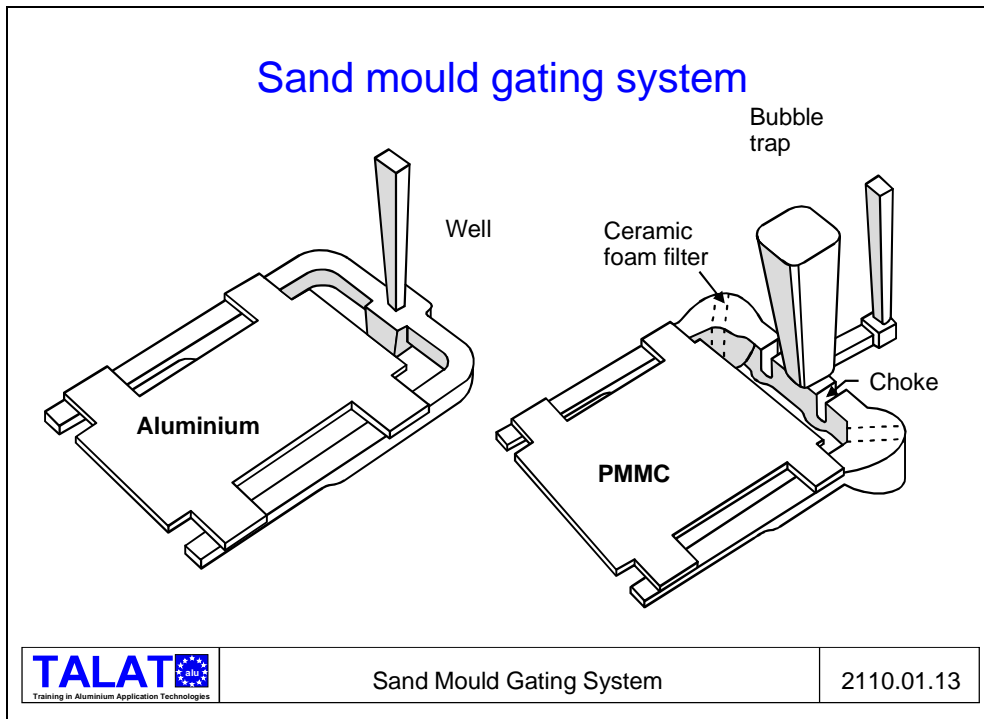

Uniform particle distribution is not always demanded for every PMMC application, and for instance the particle pushing due to slow solidification in a centrifugal cog wheel is probably of minor importance. Sand casting, plaster casting and other methods with slow solidification can be used to obtain local reinforcement due to particle settling. Particle settling in centrifugal casting will increase the wear resistance of the outer part of the component as illustrated in **Figure 2110.01.14** for a cogwheel.

Local Particle Reinforcement Centrifugal Casting of Cogwheel

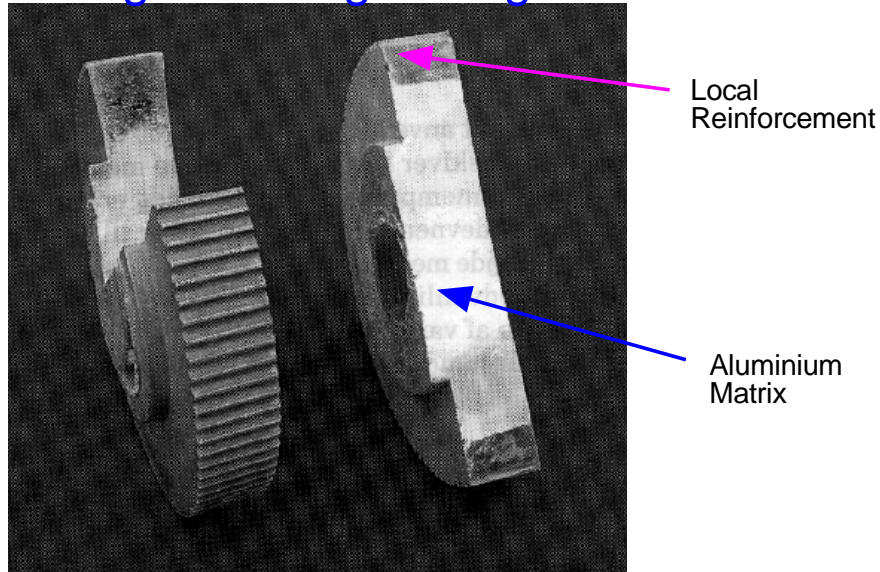

Source: Kolsgaard/ SINTEF



Local Particle Reinforcement of Cogwheels

2110.01.14

With increased volume percentage SiC-particles the fluidity of the melt will decrease, so that flow distance in the running system and the product itself matters when designing casting equipment and components (for the whole section see ⁴⁾).

Casting Methods for the PMMC

The different casting methods that are possible for PMMC component production are:

- Sand casting
- Investment casting
- Centrifugal casting
- Permanent mould casting
- High pressure die casting
- Squeeze casting

The choice of casting methods depends mainly on the number of units produced, the particle distribution and the surface, shape and material qualities. The number of units produced is presently not specified, but we assume the annual production to about 400.000 units. Sand casting and centrifugal casting are not preferable due to surface quality and manufacturability (**Figure 2110.01.15**). We also want a uniform distribution of the particles in the brake rotor. Investment casting is most preferable for small series

and is, therefore, not an option. Of the remaining casting methods we find permanent mould casting to be the best solution due to the best uniform distribution, acceptable manufacture costs and surface quality.

| Casting methods of brake rotor | | | |
|---------------------------------------|-----------------------|---------------------------------|------------------------------|
| Manufacturing Methods | Particle distribution | Surface/ shape material quality | Cost manufacturing machining |
| Sand casting | + | - | ++ ¹⁾ |
| Centrifugal | (+) | - / + | ++ ¹⁾ |
| Investment casting | + | ++ | ++ ¹⁾ |
| Permanent mould | ++ | + | ++ |
| High pressure | ++ | ++ | ++ ²⁾ |
| Squeeze casting | + | ++ | ++ ²⁾ |

¹⁾ small series ²⁾ large series

| | | |
|---|--------------------------------|------------|
|  Training in Aluminium Application Technologies | Casting Methods of Brake Rotor | 2110.01.15 |
|---|--------------------------------|------------|

Life Cycle Analysis

Our next step is to compare the environmental performance associated with the two different materials. To identify where and when the different critical environmental parameters are located, we must model the life cycle of the product. Our analysis is not supported by a specific LCA tool. We have used data from producers and publications. The example will present the simplified results.

The use of the automobile, the exploitation of the resources, the aluminium, iron and PMMC production, the reprocessing and so forth are not located at the same places. System boundaries must be established at each location because most of the environmental indexes are regional or local. Many simplifications have to be made in order to be able to compare two different materials.

A comparison of two materials for a given component is easier than analysing a whole product e.g. an automobile. The brake rotor is a part of a larger product and must, therefore, support the functional unit defined for the automobile (e.g.: material consumption - kg per automobile during its lifetime). The brake system shall provide controllable braking conditions over the whole lifetime of the automobile. The brake rotor is a replacement wear component. We want it to last as long as possible.

The average age of an automobile in Norway is 17 years. The average kilometer life-time of an automobile in Norway is 230 000 Km [1993 statistics, Opplysningsrådet for veitrafikk, Norway]. We will use 200 000 km as input in our calculations.

Life Cycle Logistics

Before an analysis can be initiated we must expose the life cycle logistics of the product for each of the two brake rotors. The life cycles of the cast iron and the PMMC brake rotors, respectively, are illustrated in **Figure 2110.01.16** and **Figure 2110.01.17**.

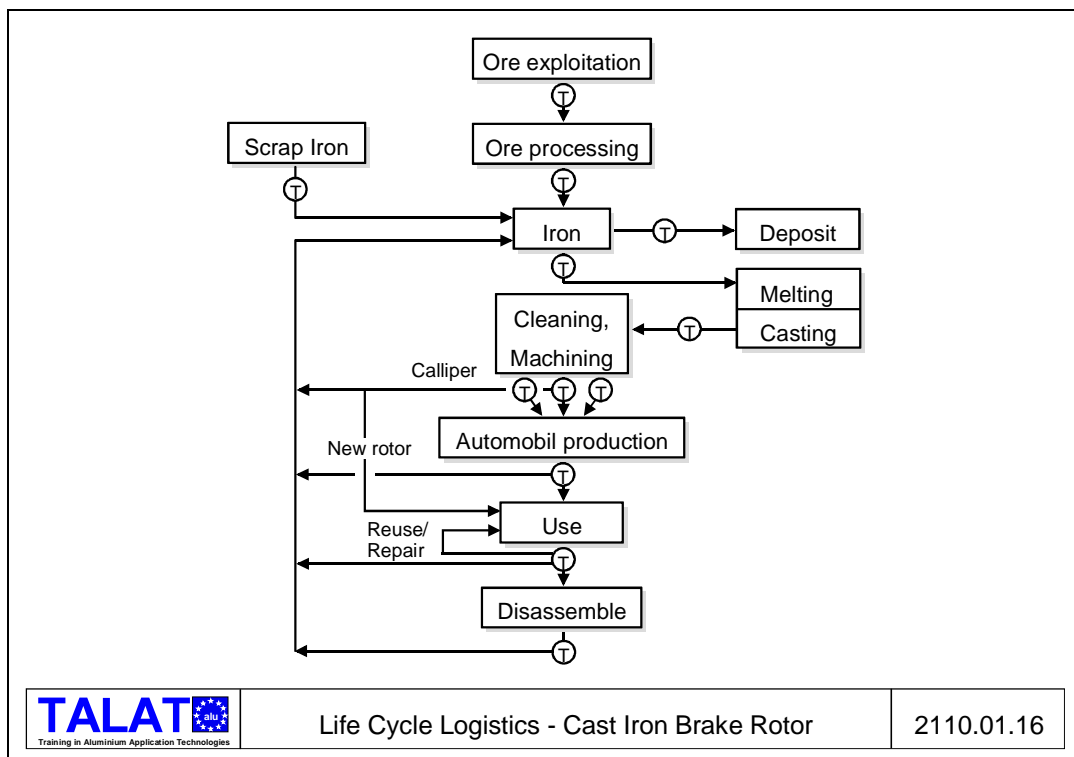

Product development

The brake rotor is designed by suppliers of automobile manufacturers. It involves paperwork and calculations. Some prototypes are produced but the environmental impacts linked to the activity are minor when considering production, use and reprocessing. No further valuation is done within the product development activity regarding the environmental impact which the physical work initiates.

Exploitation/production

Cast iron is produced from pig iron and scrapped steel. Ore is exploited from mines and crushed for iron production. Ore and coke are the two main ingredients in the iron production. Pig iron is then refined to cast iron. The use of scrapped steel varies from 50% to 100% in cast iron production for brake rotors [Valdemar Birn A/S, DK]. Iron

production produces considerable amounts of waste which are dumped altogether with neutralising materials.

The rotor is sand cast and after the sand and the core print (for ventilated brake rotors) are removed the rotor is cleaned and machined to specified measures and tolerances. The rotor is cast in Denmark and then transported to Sweden for machining. The iron brake rotor is then heat treated to attain the specified strength. After the component processing the brake rotor is transported to Volvo to be assembled into the wheel together with the calliper and the rest of the subsystems in the wheel design. After assembly the automobile is transported to the wholesaler and sold to the customer. During production scrap is reprocessed to cast iron.

PMMC: The aluminium production is based on bauxite exploitation and alumina (aluminium oxide) production. The bauxite and alumina are produced in Jamaica and

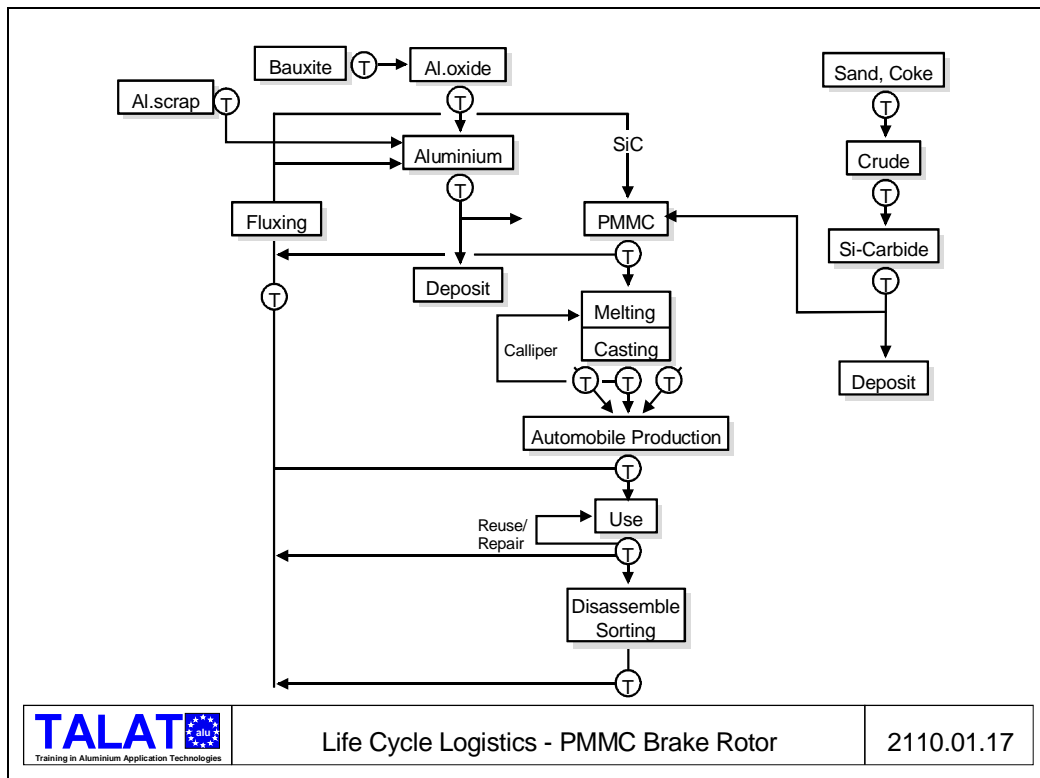

Ireland. The aluminium is then transported by ship to Sunndalsøra, Norway for aluminium production. The PMMC composite is produced at the same plant. Hydroelectric power is used to produce the aluminium and the PMMC. The bauxite is extracted from the surface and does not involve major pollution or permanent damages. The SiC-particle production is located at Lillesand, Norway. The particle production process consumes considerable amounts of energy due to the long combustion process and purification. The SiC-particles are made out of crude which is a layer of different crystals. Sand is mainly extracted in Belgium and transported to Norway for processing. Coke is mainly imported from The United States via Rotterdam, Netherlands. The coke and the sand are burned by the use of electrodes. The SiC-particles are then transported to Sunndalsøra for PMMC production. The aluminium and the SiC are mixed and

moulded into ingots, which are transported to the brake rotor producer. The PMMC scrap is fluxed (separated) in the plant. The exact location of the plant is not yet determined. The rotor is then transported to the automobile manufacturer.

Use

The brake rotor shall provide a controllable reduction of speed during use. The environmental impact linked to the use of the brake rotor are its weight which increases the gasoline consumption and the elements which are worn off during use. The lifetime of the cast iron brake rotor is considered to be half the lifetime of the car ⁷⁾. This implies a production of at least another set of brake rotors per automobile during its lifetime of approximately 200 000 km. The lifetime of the PMMC brake rotor is considered to be the same as the lifetime of the car ⁷⁾.

Recovery

After use the automobiles are disassembled and scrapped for iron production. The parts which are reusable will be dismantled from the rest of the automobile. The recovery of the component depends on the properties of the used part. The rest of the automobile is then scrapped. Steel and cast iron parts are recycled. The cast iron brake rotor is mainly made out of scrapped steel. The PMMC rotor is recyclable and has to be labeled for sorting. It is extremely difficult to trace each automobile to find the specific recycling route of the brake rotor. We assume that an automobile in Norway will be scrapped in Norway. The PMMC brake rotors must be transported to the PMMC plant for separation. The SiC-particles are reused.

The next step in the life cycle analysis is to quantitatively identify the environmental impacts that are linked to the life cycles of the brake rotors.

Life Cycle Analysis

Our analysis has mainly served to identify the critical parameters linked to the production, use and reprocessing of the brake rotors. Data have been collected from material producers, public administration and an automobile manufacturer. The analysis is not complete, but a clear picture of the environmental impact is established.

The data for the cast iron and the PMMC brake rotor include:

- Energy consumption of processing and reprocessing
- Material consumption
- Reliability and safety considerations
- Life cycle costs
- Pollution from production, use and reprocessing

Transport, assembly and disassembly costs have not been included in the inventory analysis. Pollution from transport has been roughly estimated. Deposits have not been fully documented and are, therefore, not included in the calculations. Pollution from machining, assembly, disassembly and sorting have not been included in the inventory

analysis. Pollution from silicium carbide production has not been documented and implemented.

During the use of the automobile we have specified dampened non-rotating mass to evaluate the gasoline consumption. Indices for non-dampened rotating mass do not exist. Production of PMMC brake rotors is not yet established, but prototypes have been made. Testing of PMMC brake rotor has been executed at Sintef, Norway.

Comparison

Energy Consumption

The cast iron brake rotors are basically made out of scrapped steel and iron. Aluminium and SiC-particle production demand three times as much energy as the iron production of 7 kWh, but consume a fifth (5 kWh) when recycled due to the low melting temperature of aluminium. An overview is given in the table below (see also **Figure 2110.01.18**). The fluxing is not included in the energy balance. When reprocessing the PMMC the SiC-particles are 100% reused.

| Consumption overview | | | | |
|---------------------------------------|-----------|----------------|--|---------|
| Material Parameters | Cast iron | | SiC Particle reinforced Metal Matrix Composite | |
| | Ore iron | Scrapped steel | Aluminium | SiC |
| Energy consumption processing | | 8.0 kWh | 22.0 kWh | 2.0 kWh |
| Energy consumption reprocessing | | 5.0 kWh | 1.5 kWh | |
| Material consumption raw material | 12.0 Kg | 7.0 Kg | 6.0 Kg Bauxite | 0.3 Kg |
| Material consumption refined material | | 6.5 Kg | 1.4 Kg | |
| Material consumption end product | | 4.5 Kg | 1.5 Kg | |
| Reliability & safety | Good | | Good | |
| Product life time | 100.00 Km | | 200.000 Km | |

Sources: Vald, Birn, Denmark/ Hydro Aluminium, Norway/ Norton, Norway/ Sintef

| | | |
|---|----------------------|------------|
|  | Consumption Overview | 2110.01.18 |
|---|----------------------|------------|

Material consumption

The end products dictate a consumption of 7 kg scrapped iron, 1.7 kg aluminium and 0.3 kg SiC, respectively. The tested PMMC and cast iron rotors are 1.5 and 4.5 kg, respectively. Both the cast iron and PMMC brake rotors are 100% recyclable. The iron production and the following casting process produce more deposit than the PMMC production. No conclusions can be made regarding land exploitation.

Reliability and Safety

The production and reprocessing of the two alternative materials will not be considered in this perspective. The brake rotor performance is a part of the function to give a controllable reduction of speed. Both the cast iron and the PMMC brake rotors satisfy the test requirements. The cast iron rotor is less reliable and does not provide the same safety at the end of its „life“. The PMMC brake rotor has a lifetime of four times the cast iron rotor [full scale test, Sintef]. Conclusions regarding the reliability and safety demand further investigation.

Life Cycle Cost

The production cost for the PMMC rotor exceeds that for the cast iron rotor. Calculations ⁸⁾ indicate larger material costs for the PMMC rotor as well. Due to the longer lifetime of the PMMC rotor, however, the life cycle cost is half that of the cast iron rotor (see **Figure 2110.01.19**). The calculation is made for an automobile lifetime and will, if the brake rotor of PMMC is reused in another automobile, become more profitable for the PMMC material. Besides the reduction of the life cycle cost of the brake rotor itself, the weight reduction is assumed to influence the cost of the other internal systems of the wheel positively.

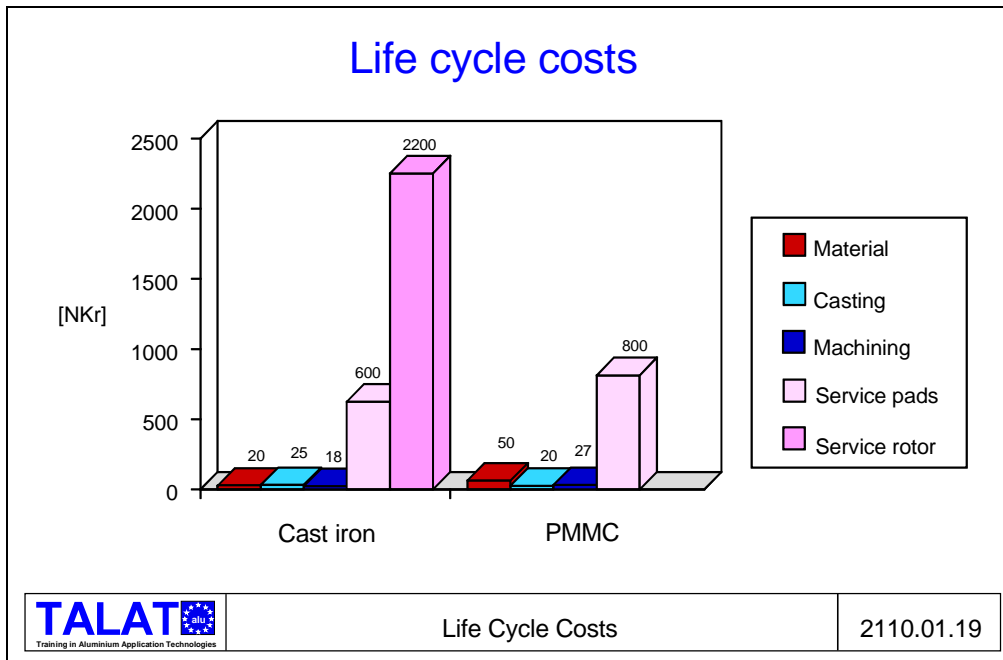

Pollution

The use of the automobile is the main mode to air pollution. We have estimated an average consumption of gasoline with catalyzer of 0,8 litres per 10 km over a period of 200 000 km. The pollution from the automobile exceeds the pollution from transport considerably. We have estimated a representative truck transport mode by 2000 km over the whole life cycle. The representative cargo weight is assumed to be 20 tonnes. It indicates approximately a consumption of 0,1 litre diesel per brake rotor.

The air pollution (CO_2 , CO, NO_x and HC) from the use of the automobile exceeds the processing and reprocessing, respectively, by approximately 1000 times except in the case of the SO_2 and dust emission. This includes especially the SO_2 emission from the aluminium production which is 4.7 kg per automobile. Our estimates indicate a small decrease in air pollution when using PMMC rotors on all four wheels. The calculations include dampened non-rotating mass (**Figure 2110.01.20**).

Air pollution from use of automobile

| Elements | Cast iron | PMMC | Reduction |
|-----------------|-----------|---------|-----------|
| CO | 368.0 | 366.2 | 1.8 |
| HC | 44.8 | 44.6 | 0.2 |
| NO _x | 110.4 | 109.8 | 0.6 |
| Dust | 0 | 0 | |
| CO ₂ | 36800.00 | 36616.7 | 183.3 |

Unit: Kg/ 200 000 Km
 Fuel: Gasoline with use of catalysator
 Dampened non-rotating mass

Source: State pollution Control Authority, Norway/ Volvo car corporation



Air Pollution from Use of Automobile

2110.01.20

A dampened non-rotating mass reduction of 1 kilogram is estimated to reduce the gasoline consumption of 8,3 kg when the driving distance is 200 000 km [Volvo]. This is a non-conservative measure since the reduction of the weight, the air resistance of the automobile body and the transmission are included in the 8,3 kilogram reduction. Because the brake rotors are non-dampened rotating mass we consider our result to be extremely conservative.

A weighted comparison grounded in the indexes of the Simapro 2.0 LCA software tool is shown in **(Figure 2110.01.21)**. Simapro uses the ecopoints methodology developed by Buwal. Our model was adjusted for the Netherlands. The comparisons only involve air pollution and indicate no difference between cast iron and PMMC brake rotors. The aluminium production process is not favourable due to the SO₂ emission.

Weighted comparison - air pollution

| Activities Elements | Factor | Processing | Transport | Use | Reproc. | Total |
|-------------------------------|--------|------------|-----------|---------|---------|---------|
| Cast iron brake rotors | | | | | | |
| CO | 0.0059 | 0.02 | 0.02 | 217.12 | 0.02 | 217.17 |
| HC | 1.00 | 0.08 | 0.06 | 368.00 | 0.08 | 368.22 |
| NO _x | 9.89 | 0.08 | 0.79 | 1087.79 | 0.08 | 1088.74 |
| CO ₂ | 32.62 | 0.52 | | | 0.52 | 1.04 |
| PMMC brake rotors | | | | | | |
| CO | 0.0059 | 0.0 | 0.01 | 216.03 | 0 | 216.04 |
| HC | 1.00 | 0.07 | 0.02 | 366.00 | 0 | 366.04 |
| NO _x | 9.89 | 1.31 | 0.2 | 1087.79 | 0.28 | 1089.09 |
| CO ₂ | 32.62 | 153.97 | | | 0.39 | 154.36 |

Solid waste not included / Pollution from SiC production not included

Transport involves rough estimates

Sources: Simapro 2.0/ Stenness/ Vald. Birn/ Volvo/ State Pollution Control Authority, Norway



Weighted Comparison - Air Pollution

2110.01.21

Another LCA study, with indexes from Volvo car corporation, indicates a better environmental performance of the PMMC rotors. The analysis is made with the use of the Environmental Priority System (EPS) which use Environmental Load Units per unit (e.g. ELU/kg for materials used) as indices for construction materials and manufacturing processes during the life cycle of the object. ELU is defined as the willingness to pay avoiding negative effects on biodiversity, human health, production, resources and aesthetic values. One ELU corresponds roughly to one ECU on the OECD countries. The EPS study (**Figure 2110.01.22**) does not involve the following:

- Transport modes
- Silicium carbide processes
- Deposit and
- Recovery of PMMC component when life-time of automobile is 200 000 km.

The EPS supports the earlier result that the use of the automobile holds the main environmental impact in the life cycle. In the case of the cast iron the use of the automobile holds approximately 90% of the total ELU index while aluminium PMMC brake rotors hold approximately 65% of the total. The ELU of the cast iron brake rotor is three times the ELU of the PMMC rotor.

Our EPS study has used the weight saving definition, 4 rake rotors and dampened non-rotating mass.

EPS Values

| Processes | Production | Use | Recovery component | Recovery material | Total |
|----------------------------|------------|--------|--------------------|-------------------|---------------|
| Aluminium | 21.54 | | | -17.22 | 4.32 |
| Lead free gasoline Casting | 0.30 | 40.84 | | | 40.84 0.3 |
| Total | | | | | 45.46 |
| Cast iron | 24.84 | | | -12.60 | 12.24 |
| Lead free gasoline Casting | 0.60 | 122.51 | | | 122.51 0.6 |
| Total | | | | | 135.35 |

Index unit: ELU

Source: Volvo car corporation



EPS Values

2110.01.22

Concluding LCA Remarks

The inventory analysis has revealed that the use of the automobile is the main pollution mode. This is because of the clarification of the EPS values, the conservatism of the defined mass (non-rotating and dampened) and the pollution rates connected to the use of the automobile. The longer lifetime (exceeding 200 000 km) of the PMMC rotor affects costs, material consumption, energy consumption and pollution rates positively. The uncertainty linked to the rough transport estimated, the lack of deposit, solid waste, the SiC-process, assembly, and disassembly data indicate the need for a more comprehensive evaluation. Due to the above mentioned reasons we conclude that the PMMC has the best environmental performance.

Our next step is to investigate the material properties of the two solutions.

Material properties

As described earlier the PMMC brake rotor has a life-time which is four times the life-time of the cast iron rotor. This is the conclusion from a research project at Sintef, Norway (**Figure 2110.01.23**).

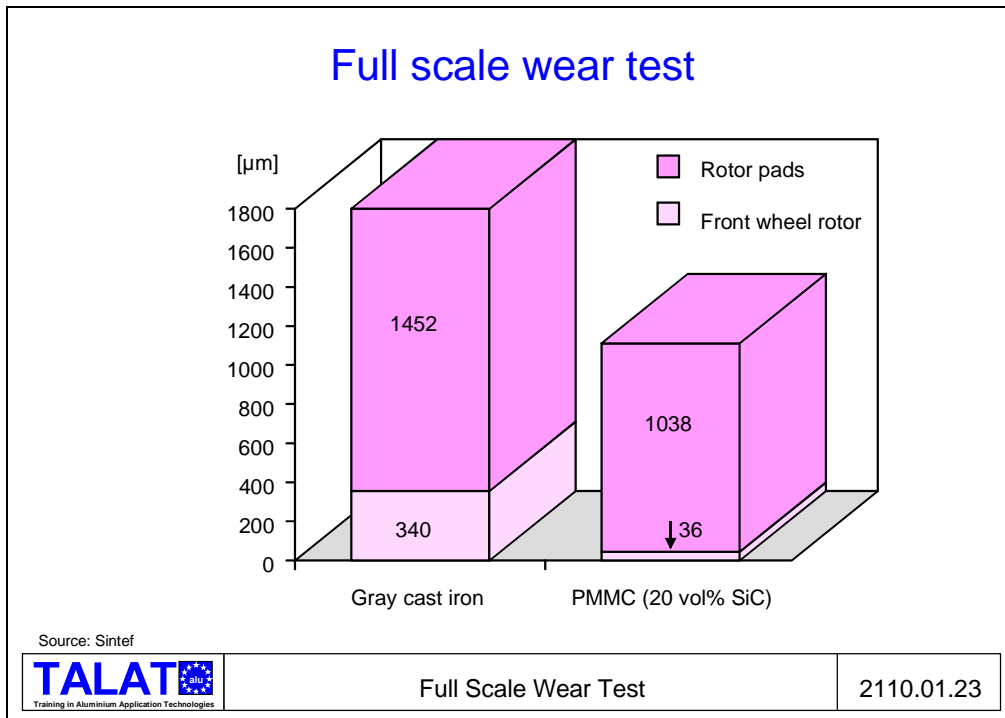

The increased wear resistance dictates a longer rotor life-time which influences the life cycle parameters positively. The PMMC rotor has the lowest noise level during use and it has the best outcome concerning the environmental life cycle parameters (the universal virtues). The PMMC has a better corrosion resistance than the cast iron and holds approximately the same yield strength as illustrated in the table below (**Figure 2110.01.24**).

Composite material selection

| Material Properties | Gray cast iron | SiC - particle reinforced aluminium composite | | |
|-------------------------------------|----------------|---|-------------|-------------|
| | | 0 vol% SiC | 10 vol% SiC | 20 vol% SiC |
| Thermal conductivity [W/m K] | 48 | 155 | 175 | 180 |
| Yield strength [MPa] | 330 | 200 | 290 | 320 |
| Thermal exp. coeff. [$10^{-6}/K$] | 12 | 23 | 19 | 19 |
| Density [g/cm^3] | 7.25 | 2.8 | 2.73 | 2.76 |
| Modulus of elasticity [GPa] | 120 | 73 | 85 | 100 |

Source: Sintef/ Kolsgaard

TALAT Training in Aluminium Application Technologies

Composite Material Selection

2110.01.24

The increase in corrosion resistance influences the cost accounts and the safety aspects positively. The PMMC holds a considerable higher thermal conductivity and will, therefore, transfer the energy more efficiently to the surroundings. The working temperature for the PMMC is below the melting temperature. The thermal expansion coefficient for the PMMC is twice that of the cast iron. When designing a PMMC brake rotor we must consider the increase in thermal expansion. A PMMC rotor will, therefore, not be identical to the cast iron rotor.

Both brake rotor materials satisfy our requirements. We choose the PMMC material for the brake rotor because it satisfies the specified properties better than the cast iron.

Because of the decrease in ductility when adding silicium particles and minor change of wear resistance we select 10 vol. % silicium carbide to our brake rotors.

Prototypes of brake rotor and drums are illustrated in **Figure 2110.01.25**.

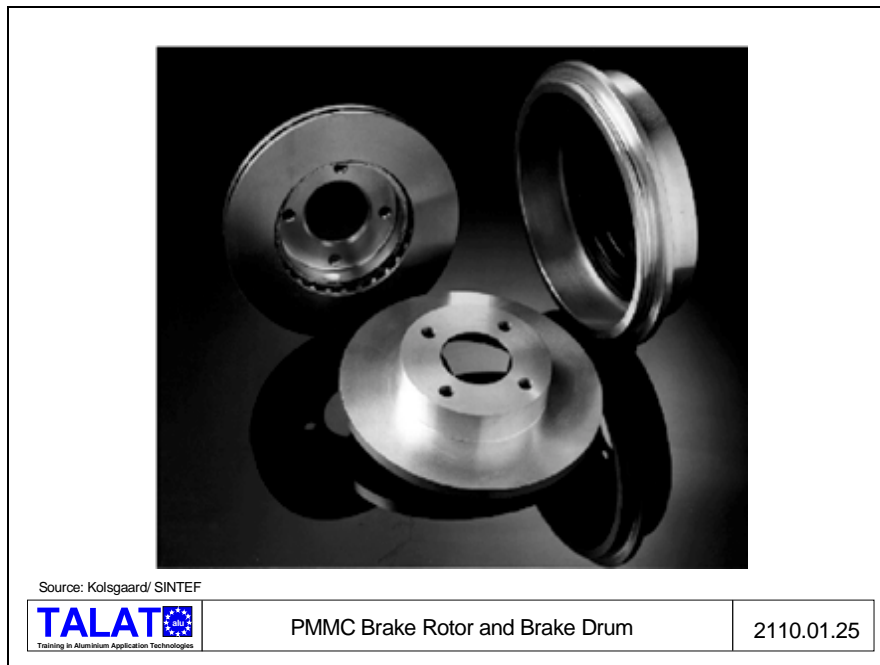

Production of the PMMC brake rotor is not established. We have made prototypes for the testing of casting methods and wear properties. The production and casting of PMMC involves new technology and thorough preparations are needed before it can be put into production. Automobile manufacturers must be a part of the process defining the end product for full scale production.

Conclusion

We have arrived at a solution that satisfies our basic specifications. Life cycle considerations and material properties have been decisive for our choice of solution.

Cast iron is mainly used as the material for automobile brakes today. There is reason to expect that the automotive industry will implement the PMMC brake rotor concept due to environmental standards that tend to amplify the importance of PMMC's light weight, excellent wear resistance and recyclability properties (**Figure 2110.01.26**).

| | | |
|--|--------------------------------|------------|
| Conclusions - PMMC brake rotor | | |
| <ul style="list-style-type: none">● Low weight● Recyclable● Low environmental impact● High wear resistance - long life time | | |
|  | Conclusions - PMMC Brake Rotor | 2110.01.26 |

References

1. **Göring, E., von Glasner, E. C.:** Improvement of the braking performance of heavy duty commercial vehicles by using brake rotors, Brake rotors for commercial vehicles, Proceedings of the Institution of Mechanical Engineering, 1988
2. **Burckhardt, Manfred:** Fahrwerktechnik - Bremsdynamik und PKE - Bremsanlagen, Vogel Buchverlag, 1991.
3. **Reimpell, Jörn:** Kraftfahrzeugtechnik, Vogel Fachbuch, 1991.
4. **Kolsgaard, Axel (PhD. thesis):** Casting characteristics of SiC particulate reinforced AlSiMg aluminium matrix composites, University of Trondheim, The Norwegian Institute of Technology, Department of Machine Design and Materials Technology, 1994.
5. **Støren, Sigurd & Andreassen, Mogens Myrup:** Know Your Product, not published, 1994.
6. **Støren, Sigurd:** Sustainable business Concept, not published, 1994.
7. Sintef: Tribological applications of PMMC Composite (in Norwegian), Sintef, Trondheim, Norway, 1994.

8. **Stemnes, Per Ivar** (Thesis): Particle reinforced aluminium - LCA of brake rotor with emphasis on recycling (in Norwegian), University of Trondheim, The Norwegian Institute of Technology, Department of Materials Technology, 1992.
9. **Berglund, Sixten**: Thesis: Life Cycle Assessment - Environmental considerations in design work, Institutionen för Maskin -och Fordonskonstruktion (in Swedish), Chalmers Tekniska Högskola (in Swedish), 1992.
10. **Olsson, Leif**: The environmental aspects from the car during production, usage and destruction, paper presented at NTVA - conference, January 1994, Trondheim, Norway.

List of Figures

| Figure No. | Figure Title (Overhead) |
|-------------------|--|
| 2110.01.01 | The Automobile Brake Rotor |
| 2110.01.02 | The Product Chromosome |
| 2110.01.03 | The Process Chromosome |
| 2110.01.04 | The Wheel Design - Available Space |
| 2110.01.05 | The Wheel Design - Components |
| 2110.01.06 | Brake Rotor |
| 2110.01.07 | Function and Requirements |
| 2110.01.08 | Properties |
| 2110.01.09 | Material Properties |
| 2110.01.10 | Possible Materials |
| 2110.01.11 | SiC - Particle Reinforced Aluminium Microstructure |
| 2110.01.12 | PMMC Production Process |
| 2110.01.13 | Sand Mould Gating System |
| 2110.01.14 | Local Particle Reinforcement of Cogwheel |
| 2110.01.15 | Casting Methods of Brake Rotor |
| 2110.01.16 | Life Cycle Logistics - Cast Iron Brake Rotor |
| 2110.01.17 | Life Cycle Logistics - PMMC Brake Rotor |
| 2110.01.18 | Consumption Overview |
| 2110.01.19 | Life Cycle Costs |
| 2110.01.20 | Air Pollution from Use of Automobile |
| 2110.01.21 | Weighted Comparison - Air Pollution |
| 2110.01.22 | EPS Values |
| 2110.01.23 | Full Scale Wear Test |
| 2110.01.24 | Composite Material Selection |
| 2110.01.25 | PMMC Brake Rotor and Brake Drum |
| 2110.01.26 | Conclusions - PMMC Brake Rotor |